

WARNING

THE FOLLOWING SERVICING INSTRUCTIONS ARE FOR USE BY QUALIFIED PERSONNEL ONLY. TO AVOID PERSONAL INJURY, DO NOT PERFORM ANY SERVICING OTHER THAN THAT CONTAINED IN OPERATING INSTRUCTIONS UNLESS YOU ARE QUALIFIED TO DO SO.

<http://www.ebaman.com>

214 STORAGE OSCILLOSCOPE SERVICE

INSTRUCTION MANUAL

Tektronix, Inc.
P.O. Box 500
Beaverton, Oregon 97077

Serial Number _____

070-1483-00

First Printing AUG 1973
Revised APR 1981



Copyright © 1973 Tektronix, Inc. All rights reserved.
Contents of this publication may not be reproduced in
any form without the written permission of Tektronix, Inc.

Products of Tektronix, Inc. and its subsidiaries are
covered by U.S. and foreign patents and/or pending
patents.

TEKTRONIX, TEK, SCOPE-MOBILE, and  are
registered trademarks of Tektronix, Inc. TELEQUIP-
MENT is a registered trademark of Tektronix U.K.
Limited.

Printed in U.S.A. Specification and price change
privileges are reserved.

TABLE OF CONTENTS

SECTION 1	INTRODUCTION	Page
	General Information	1-1
	Specifications	1-1
	Vertical Deflection System	1-1
	Triggering	1-2
	Horizontal Deflection System	1-2
	Display	1-2
	Isolation	1-2
	AC Operation	1-3
	Internal Battery Operation	1-3
	Environmental	1-4
	Physical	1-4
SECTION 2	FUNCTIONS OF CONTROLS AND CONNECTORS	
	Front Panel Controls	2-1
	Side Panel Controls	2-2
SECTION 3	MAINTENANCE	
	Introduction	3-1
	Preventive Maintenance	3-1
	General	3-1
	Cleaning	3-1
	Lubrication	3-1
	Visual Inspection	3-1
	CRT Care	3-1
	Recalibration Information	3-2
	Disassembly Instructions	3-2
	Troubleshooting	3-3
	Introduction	3-3
	Troubleshooting Aids	3-3
	Troubleshooting Equipment	3-3
	Corrective Maintenance	3-3
	Obtaining Replacement Parts	3-3
	Component Replacement	3-4
	Recalibration After Repair	3-6
	Instrument Repackaging	3-6

TABLE OF CONTENTS (cont)

SECTION 4 CALIBRATION	Page
General	4-1
Test Equipment Required	4-1
Special Calibration Fixtures	4-1
Preliminary Procedure	4-3
Preliminary Control Settings	4-3
Power Supply and Display	4-4
Check Power Supply DC Levels	4-4
Adjust CRT Grid Bias	4-5
Adjust FOCUS	4-5
Adjust Trace Rotation	4-5
Adjust Storage Operating Level	4-5
Adjust Wall Band Level	4-6
Adjust Enhance Level	4-7
Adjust Hum Balance	4-7
Vertical System	4-8
Adjust Vertical DC Centering	4-8
Adjust Channel 1 Step Attenuator Balance	4-8
Adjust Channel 2 Step Attenuator Balance	4-8
Adjust Vertical Gain	4-9
Adjust Storage Vertical Gain	4-9
Check Channel 2 Variable Volts/Division Range	4-9
Check Channel 2 Volts/Division Accuracy	4-9
Check Input Coupling Switches	4-10
Check CH 1 Volts/Division Accuracy and Variable Volts/Division Range	4-10
Check Channel 1 Volts/Div Compensation	4-10
Check Channel 2 Volts/Div Compensation	4-11
Check Vertical Amplifier Bandwidth	4-12
Trigger Circuit	4-13
Adjust AUTO PRESET Level	4-13
Check Trigger Circuit Operation	4-13
Check Single Sweep Operation	4-13
Horizontal System	4-15
Adjust Horizontal Centering	4-15
Adjust Horizontal Gain	4-15
Adjust Sweep Calibration	4-15
Check Variable Horizontal Magnifier Range	4-16
Check SEC/DIV Accuracy	4-16

TABLE OF CONTENTS (cont)

SECTION 5	TROUBLESHOOTING AIDS	Page
	Diagram Information	5-1
	Component Color Coding	5-1
	Troubleshooting Equipment	5-1
SECTION 6	CIRCUIT DESCRIPTION	
	Block Diagram Description	6-1
	Circuit Operation	6-1
	Vertical Input Amplifiers	6-3
	Vertical and Horizontal Output Amplifiers	6-3
	Trigger Generator	6-3
	Sweep Generator	6-3
	Single Sweep	6-3
	Storage	6-4
	Power Supply	6-7
	CRT Circuit	6-9
SECTION 7	DELETED	
	(INFORMATION NOW INCORPORATED IN SECTION 3)	
SECTION 8	ELECTRICAL PARTS LIST	
	OPTION INFORMATION	
SECTION 9	DIAGRAMS AND CIRCUIT BOARD ILLUSTRATIONS	
SECTION 10	MECHANICAL PARTS LIST	
	CHANGE INFORMATION	

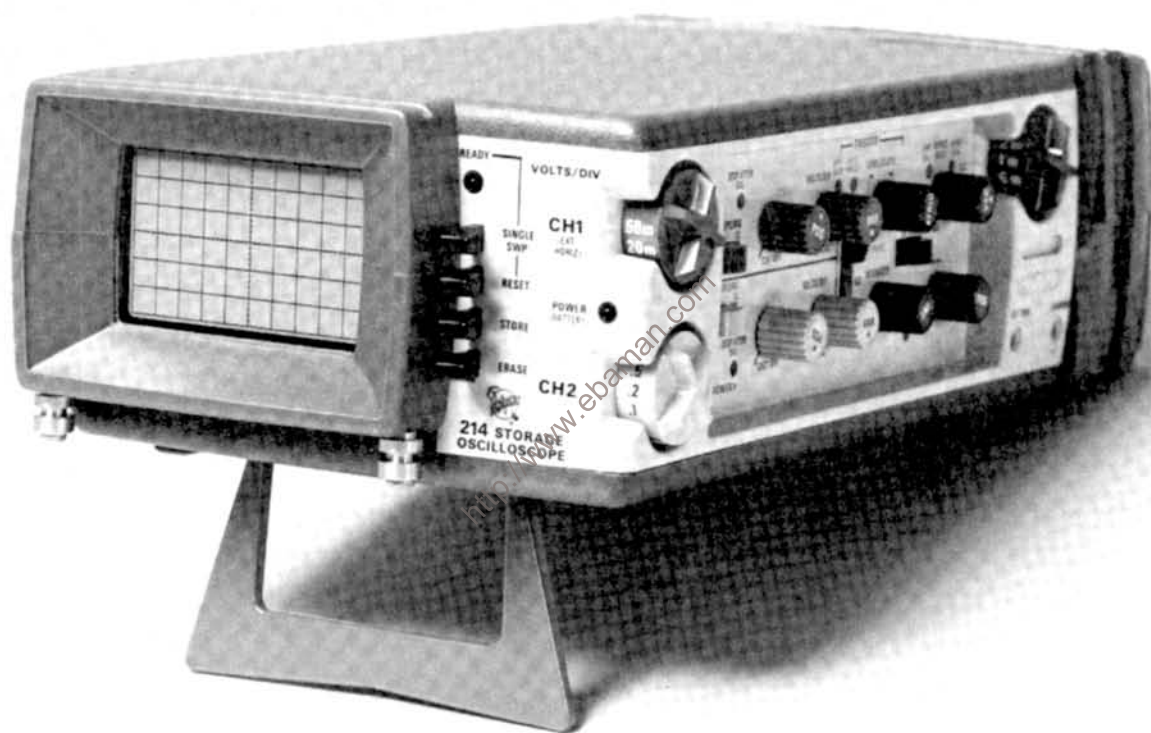

Tektronix 214 Storage Oscilloscope.

INTRODUCTION

GENERAL INFORMATION

The Tektronix 214 Storage Oscilloscope is a solid-state portable instrument that combines small size and light weight with the ability to make precision waveform measurements. It is designed for general-purpose applications where display storage is desired, along with conventional (NONSTORE) operation. The instrument is mechanically constructed to withstand the shock, vibration, and other extremes associated with portability.

The dual-channel DC-to-500 kilohertz vertical system provides vertical deflection factors from one millivolt (at a reduced bandwidth) to 50 volts/division at the tip of either of the integral high-impedance probes. The 214 will either automatically chop or alternate, depending upon the sweep rate. Single-trace operation is achieved by turning off either channel with its position control. Single Sweep operation is provided to display infrequently recurring events. The trigger circuit provides stable triggering over the full range of vertical frequency response.

The horizontal deflection system provides calibrated sweep rates from 500 milliseconds to five microseconds/division. Uncalibrated sweep rates, via a variable sweep magnifier, are available to at least five times the indicated sweep rate for a maximum of at least one microsecond/division. Stored Automatic Enhance occurs (in the Single Sweep mode) at sweep rates of 0.1 millisecond/division and faster.

X-Y operation is provided with Channel 1 supplying the horizontal deflection of the applied (X) signal, with a range from less than one millivolt to 50 volts/division (at a reduced bandwidth of 50 kilohertz). Channel 2 supplies the vertical deflection of the applied (Y) signal.

The cathode-ray tube (CRT) is a direct-view bistable Storage tube having a 6 X 10 division graticule (each division equals 0.203 inch).

The 214 is operated either from AC line voltage or from internal rechargeable batteries. The internal batteries are recharged from the AC power line by the integral battery charger (with the instrument OFF).

This instrument will meet the following electrical characteristics after complete instrument calibration. These characteristics apply over an ambient temperature range of -15°C to $+55^{\circ}\text{C}$ ($+5^{\circ}\text{F}$ to $+131^{\circ}\text{F}$) when operating from the internal batteries, and 0°C to $+40^{\circ}\text{C}$ ($+32^{\circ}\text{F}$ to $+104^{\circ}\text{F}$) when operating from an AC line source, except as otherwise indicated. Warmup time for given accuracies is five minutes.

SPECIFICATIONS

Vertical Deflection System

DEFLECTION FACTOR:

Calibrated Range: One millivolt to 50 volts/division. 15 steps in a 1-2-5 sequence.

Accuracy: Within 5% with VAR VOLTS/DIV control in CAL position and gain correctly set at five millivolts/division.

Uncalibrated (variable) Range: Continuously variable between calibrated settings. Extends maximum deflection factor to at least 125 volts/division.

BANDWIDTH (using six-division reference):

10 mV/DIV to 50 V/DIV: DC to at least 500 kilohertz.

5 mV/DIV: DC to at least 400 kilohertz.

2 mV/DIV: DC to at least 200 kilohertz.

1 mV/DIV: DC to at least 100 kilohertz.

Lower Bandwidth Limit, AC (capacitively) Coupled: About two hertz at all deflection factors.

INPUT RESISTANCE: One megohm, within 5%.

INPUT CAPACITANCE:

1 mV/DIV to 50 mV/DIV: Approximately 160 picofarads.

100 mV/DIV to 50 V/DIV: Approximately 140 picofarads.

Introduction—214 Service

MAXIMUM USABLE INPUT VOLTAGE:

50 V/DIV to 0.1 V/DIV: 600 volts (DC + peak AC). 600 volts peak-to-peak AC (five megahertz or less).

50 mV/DIV to 1 mV/DIV: 600 volts (DC + peak AC). AC not over two kilohertz or risetime not less than 100 nanoseconds.

CHOPPED MODE: From 500 ms/DIV to 2 ms/DIV of time rate at approximately 40 kilohertz.

ALTERNATE MODE: From 1 ms/DIV to 5 μ s/DIV of time rate.

INPUT IMPEDANCE MATCHING: Matched to within 10%.

GAIN ACCURACY BETWEEN CHANNELS: Within 5% with both VAR VOLTS/DIV controls in CAL position and gain correctly set at 5 mV/DIV.

Triggering

TRIGGER SENSITIVITY:

Internal:

COMP: 0.2 division from DC to 500 kilohertz.

CH 2: 0.2 division from 2 hertz to 500 kilohertz.

External: At least one volt from DC to 500 kilohertz.

PRESET TRIGGER LEVEL: Triggered at preset level on positive slope of triggering signal. Sensitivity same as stated above.

DISPLAY JITTER: 0.5 microsecond or less at 500 kilohertz.

EXTERNAL TRIGGER:

Input Resistance: Approximately one megohm.

Input Capacitance: Approximately 30 picofarads.

Maximum Usable Input Voltage: Eight volts (DC + peak AC). 16 volts peak-to-peak AC (one megahertz or less).

Horizontal Deflection System

SWEEP RATE:

Calibrated Range: 500 milliseconds to five microseconds/division, 16 steps in 1-2-5 sequence.

Accuracy (over center eight divisions): Within 5% with VAR HORIZ MAG control in CAL position and timing correctly set at 1 ms/DIV (disregard first 0.5 microsecond of sweep length).

Linearity (any two division portion within center eight divisions): Within 5% (disregard first 10% of total sweep length).

Variable Magnifier; Continuously variable between calibrated settings. Extends maximum sweep rate to at least one microsecond/division.

CH 1 HORIZONTAL INPUT:

Calibrated Deflection Factor: One millivolt to 50 volts/division.

Variable: At least five times magnification (using VAR HORIZ MAG).

Accuracy: Within 10% (with VAR HORIZ MAG in CAL).

X-Y Phasing: Less than 3° to five kilohertz.

Maximum Input Voltage: Same as for CH 1 (vertical).

Display

GRATICULE:

Type: Internal Black line, non-illuminated.

Area: Six divisions vertical by 10 divisions horizontal. Each division equals 0.203 inch.

Stored Writing Speed

At least 80 divisions/millisecond. At least 500 divisions/millisecond in Automatic Enhance (internal adjustment).

Isolation

INPUT COMMON TO 214 CASE EXTERIOR: (When battery operated with AC power plug secured in the insulated cover.) Maximum floating potential between input common and 214 case exterior is not to exceed 500 volts RMS sinusoidal or 700 volts (DC + peak AC).

INPUT COMMON TO AC LINE: Maximum floating voltage plus AC line voltage is not to exceed 250 Volts RMS

sinusoidal, or 1.4 times the AC line voltage plus (DC + peak AC) is not to exceed 350 volts

AC Operation

CAUTION

Due to the capacitive line input circuit, sudden voltage changes may cause damaging input current transients. Avoid operating this instrument from square-wave inverter supplies, or other sources that produce large voltage transients.

LINE VOLTAGE RANGE:

Stored Mode: 110 to 126 volts AC. Batteries can not be charged during AC operation. Instrument can be operated between 104 and 110 volts with resulting slow discharge of internal batteries.

Nonstore Mode: 104 to 126 volts AC. Instrument can be operated without resulting discharge of internal batteries.

LINE FREQUENCY: 58 to 62 hertz.

NOTE

Refer to Option and Maintenance information for other Line Voltages and Frequencies.

MAXIMUM POWER CONSUMPTION: Three watts or less at 126 volts, 60 hertz.

Internal Battery Operation

BATTERIES: 10 rechargeable A size, nickel-cadmium cells.

CHARGE TIME (from AC line): 8 hours for full charge (instrument off during charge cycle).

POWER (BATTERY) INDICATOR: When extinguished indicates approximately five minutes of scope operating life left in the batteries.

BATTERY EXCESSIVE DISCHARGE PROTECTION: Instrument operation automatically interrupted when battery charge drops to 10 volts, ± 0.5 volt.

TYPICAL OPERATING TIME (at maximum trace intensity after full charge cycle at $+20^{\circ}\text{C}$ to $+30^{\circ}\text{C}$):

NONSTORE Mode: 3.5 to five hours. Longest operating time provided at lower trace intensity.

STORE Mode: 2.5 to 3.5 hours. Longest operating time provided at lower trace intensity.

TYPICAL CHARGE CAPACITY (in reference to charge/discharge at $+20^{\circ}\text{C}$ to $+30^{\circ}\text{C}$ or $+68^{\circ}\text{F}$ to $+86^{\circ}\text{F}$) See Table 1-1.

TABLE 1-1

Operating Temperature

Charge Temperature	-15°C ($+5^{\circ}\text{F}$)	$+20^{\circ}\text{C}$ to $+30^{\circ}\text{C}$ ($+68^{\circ}\text{F}$ to $+86^{\circ}\text{F}$)	$+55^{\circ}\text{C}$ ($+131^{\circ}\text{F}$)
0°C ($+32^{\circ}\text{F}$)	40%	60%	50%
$+20^{\circ}\text{C}$ to $+30^{\circ}\text{C}$ ($+68^{\circ}\text{F}$ to $+86^{\circ}\text{F}$)	65%	100%	85%
$+40^{\circ}\text{C}$ ($+104^{\circ}\text{F}$)	40%	65%	55%

Environmental

Temperature:

Operating from Batteries, -15°C to $+55^{\circ}\text{C}$ ($+5^{\circ}\text{F}$ to $+131^{\circ}\text{F}$)

Operating from AC Line, 0°C to $+40^{\circ}\text{C}$ ($+32^{\circ}\text{F}$ to $+104^{\circ}\text{F}$)

Non-Operating, -40°C to $+60^{\circ}\text{C}$ (-40°F to $+140^{\circ}\text{F}$)

Altitude:

Operating, to 25,000 feet (maximum operating temperature decreased by 1°C per 1,000 feet above 15,000 feet).

Non-Operating, to 50,000 feet.

Humidity (operating and non-operating): five cycles (120 hours) to 95% relative humidity in reference to MIL-E-16400F.

Shock (operating and non-operating): Tested with two shocks at 150 g, one-half sine, two millisecond duration each direction along major axes.

Physical

WEIGHT (without accessories): 3.5 pounds (1.6 kilograms)

DIMENSIONS (measured at maximum points):

Height: 3.0 inches (7.6 centimeters)

Width: 5.25 inches (13.2 centimeters)

Depth: 9.5 inches (24.1 centimeters)

<http://www.ebaman.com>

FUNCTIONS OF CONTROLS AND CONNECTORS

Controls and connectors necessary for operation of the 214 are located on the front panel and on the right side panel of the instrument. A brief description of each control and connector is given here.

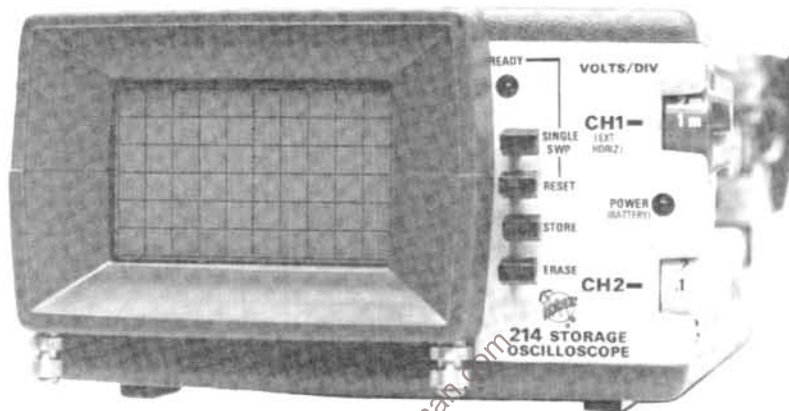

Front Panel Controls

READY Light—indicates sweep has been reset and a single display will be presented upon receipt of an adequate trigger signal.

SINGLE SWP—when pressed, the sweep operates in the Single Sweep mode. After a sweep is displayed, further sweeps cannot be presented until the **RESET** button is pressed.

RESET—when pressed and in the Single Sweep mode, a single display will be presented after correct triggering. After the sweep is completed, the **RESET** button must be pressed again before another sweep can be displayed.

NOTE

After sustained use (30 min or more) of the instrument in the Store mode with nothing written, the writing speed may be reduced. It may be improved by leaving the CRT target fully stored for five to ten minutes. This procedure may be repeated to refresh the target in applications requiring maximum stored writing rate.

STORE—when pressed, the CRT operates in the Storage mode. With the button out, the CRT operates in the conventional, **NONSTORE**, mode.

ERASE—momentary contact switch, that when pushed and released erases a Stored display from the CRT.

VOLTS/DIV—selects the vertical deflection factor in a 1-2-5 sequence (vertical **VARIABLE** must be in the **CAL** position for indicated deflection).

POWER (BATTERY)—red light to indicate when the instrument is on. When light extinguishes, battery charge is low and about five minutes of operating life remains.

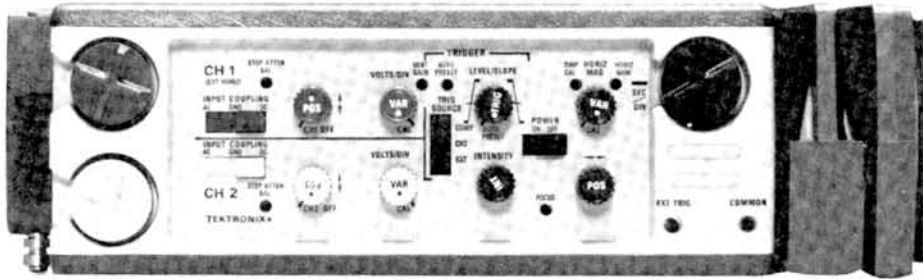

Side Panel Controls and Connectors

INPUT COUPLING—selects method used to couple the channel input signal to the vertical amplifier system.

AC—DC component of input signal is blocked. Low frequency limit (−3 dB point) is about 2 hertz.

GND—vertical amplifier input circuit is grounded. The applied signal is connected to ground through a large valve resistor to provide a precharge path for the AC input coupling capacitor.

DC—all components of the input signal are passed to the vertical amplifier system.

STEP ATTEN BAL—screwdriver adjustment to balance the vertical system for minimum trace shift when changing deflection factors.

Vertical POS—controls the vertical position of the appropriate trace. Detent turns the channel OFF.

VAR VOLTS/DIV—provides a continuously variable deflection factor between the calibrated settings of the VOLTS/DIV switch.

VERT GAIN—screwdriver adjustment to set the gain of the entire vertical system.

AUTO PRESET—screwdriver adjustment to set the PRESET trigger point for AUTO sweep operation.

TRIG SOURCE—selects the source of the trigger signal.

COMP—sweep is triggered from a DC-coupled sample of the vertical signal after the vertical switching.

CH 2—sweep is triggered from an AC-coupled sample of the CH 2 vertical signal before the vertical switching.

EXT—sweep is triggered from the DC-coupled signal applied to the EXT TRIG banana jack.

LEVEL/SLOPE—selects the amplitude point and slope of the trigger signal on which the sweep is triggered. When the indicator dot is to the left or center, the sweep is triggered on the positive-going slope of the trigger signal; to the right of center, on the negative-going slope. When the LEVEL/SLOPE control is set to the AUTO PRESET detent, the sweep is automatically triggered at a preset level on the positive-going slope.

INTENSITY—controls brightness of the CRT display.

SWP CAL—screwdriver adjustment to provide calibrated sweep timing.

POWER—controls power to the instrument. Does not interrupt charging current to the internal batteries when the instrument is connected to an AC line voltage.

FOCUS—screwdriver adjustment to obtain a well-defined display.

VAR HORIZ MAG—provides continuously variable sweep magnification to a maximum of at least five times the sweep rate indicated by the SEC/DIV switch.

HORIZ GAIN—screwdriver adjustment to set the basic gain of the horizontal system.

Horizontal POS—controls the horizontal position of the trace.

SEC/DIV—selects the sweep rate (VAR HORIZ MAG must be in CAL detent for indicated sweep rate).

EXT TRIG—banana jack to establish common ground between the 214 and the external signal source or equipment under test.

SECTION 3

MAINTENANCE

Introduction

This section of the manual contains maintenance information for use in preventive maintenance, corrective maintenance, or troubleshooting of the 214.

PREVENTIVE MAINTENANCE

General

Preventive maintenance consists of cleaning, visual inspection, lubrication, etc. When performed on a regular basis, preventive maintenance can prevent instrument breakdown and may improve the reliability of this instrument. The severity of environment to which the 214 is subjected will determine the frequency of maintenance. A convenient time to perform preventive maintenance is preceding recalibration of the instrument.

CAUTION

Avoid the use of chemical cleaning agents which might damage the plastics used in this instrument. Avoid chemicals which contain hydrochloric acid, sodium hydroxide, or sulfuric acid.

Cleaning

The 214 should be cleaned as often as operating conditions require. Accumulation of dirt in the instrument can cause component breakdown.

The high-impact plastic covers provide protection against dust in the interior of the instrument. Loose dust accumulated on these covers can be removed with a soft cloth or small brush. The brush is also useful for dislodging dirt on and around the exterior controls. Dirt that remains can be removed with a soft cloth dampened in a mild detergent and water solution. Abrasive cleaners should not be used.

Cleaning the interior should only be occasionally necessary. The best way to clean the interior is to blow off the accumulated dust with dry, low-velocity air. A soft-bristle brush or a cotton-tipped applicator is useful for cleaning in narrow spaces or for cleaning more delicate components.

Lubrication

Generally, there are no components in the 214 that require lubrication. No lubrication should be used on the contacts or rotary parts of the rotary switches. The reliability of potentiometers that are not permanently sealed can be maintained by lubrication with a lubricant that does not affect electrical characteristics (e.g., Tektronix Part No. 006-2574-00). Do not over-lubricate.

Visual Inspection

The 214 should be inspected occasionally for such defects as broken connections, improperly seated transistors, damaged circuit boards, and heat damaged parts. The corrective procedure for most visible defects is apparent; however, particular care must be taken if heat-damaged components are found. Overheating usually indicates other trouble in the instrument; therefore, correcting the cause of the overheating is important to prevent recurrence of the damage.

CRT Care

To prolong the useful life of the Storage screen, the following precautions should be observed when operating this instrument:

1. Care must be taken in the degree of writing-beam intensity that is used, particularly when using slow sweep rates, X-Y displays, or the STORE mode. Too-high beam intensity may permanently damage the CRT screen.
2. Avoid repeated use of the same area of the screen. If a particular display is being Stored repeatedly, change the vertical position occasionally to use other portions of the display area.
3. Do not leave a Stored display on the screen when it is no longer needed.
4. Operate in the NONSTORE mode unless Storage is required.

Recalibration Information

To ensure accurate measurements, check the calibration of this instrument after each 1000 hours of operation, or every six months if used infrequently. In addition, replacement of components may necessitate recalibration of the affected circuits. The calibration procedure can also be helpful in localizing certain troubles in the instrument. In some cases, minor troubles may be revealed or corrected by recalibration.

NOTE

The arrows on the probe wrap indicate the proper direction to wrap the probes and power cord. See Fig. 3-1.

Disassembly Instructions

To gain access to the interior of the instrument, unwind both probe cords and the power cord from the instrument's probe wrap at the rear of the 214.

Remove the five screws in the bottom cover of the instrument. See Fig. 3-2. Separate the bottom cover from the instrument and lay it aside. The Power Supply (A-3) circuit board, and the batteries, can be lifted up and pivoted out of the way. Most of the internal workings of the instrument are now accessible for maintenance.

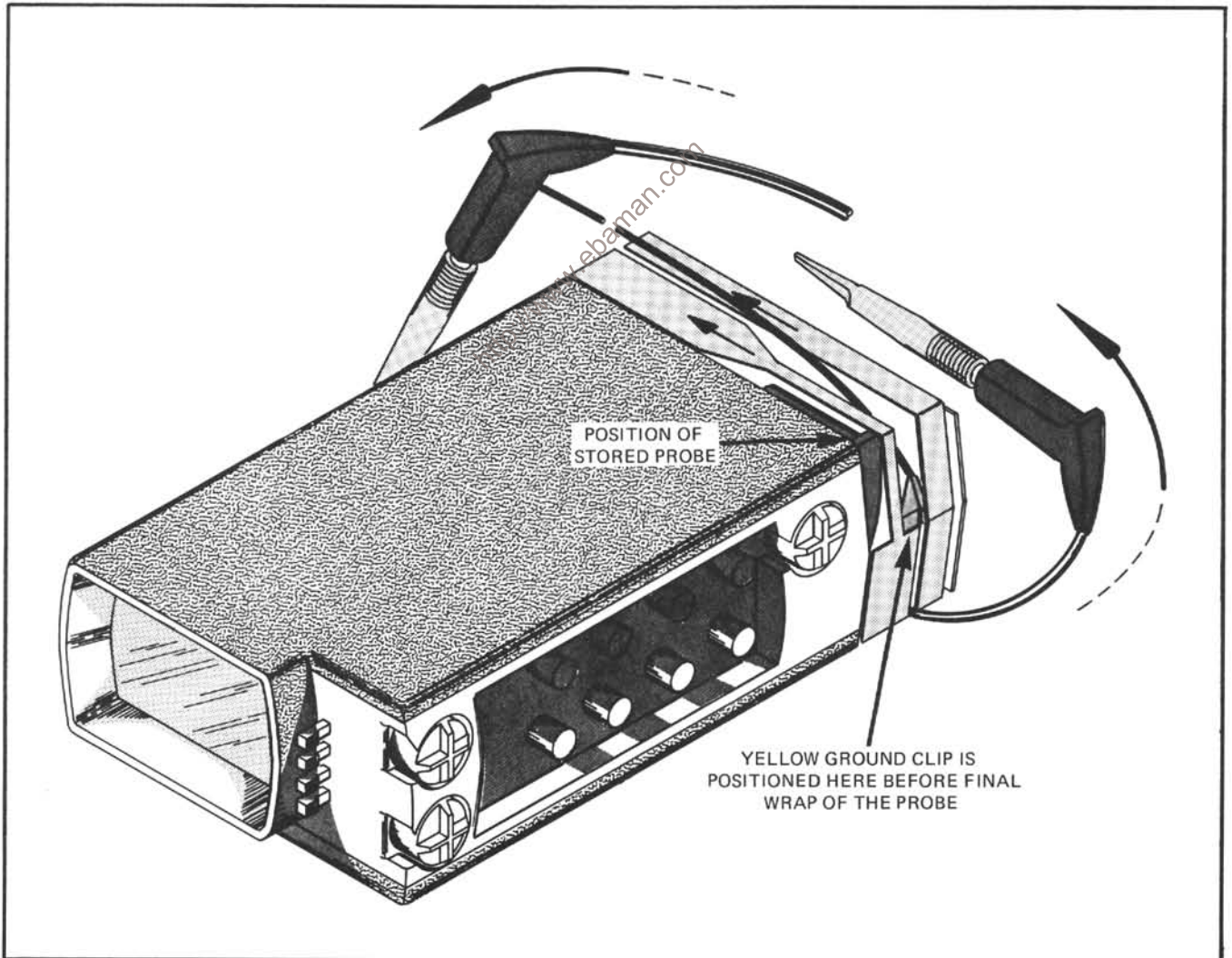

Fig. 3-1. Proper method for wrapping probes.

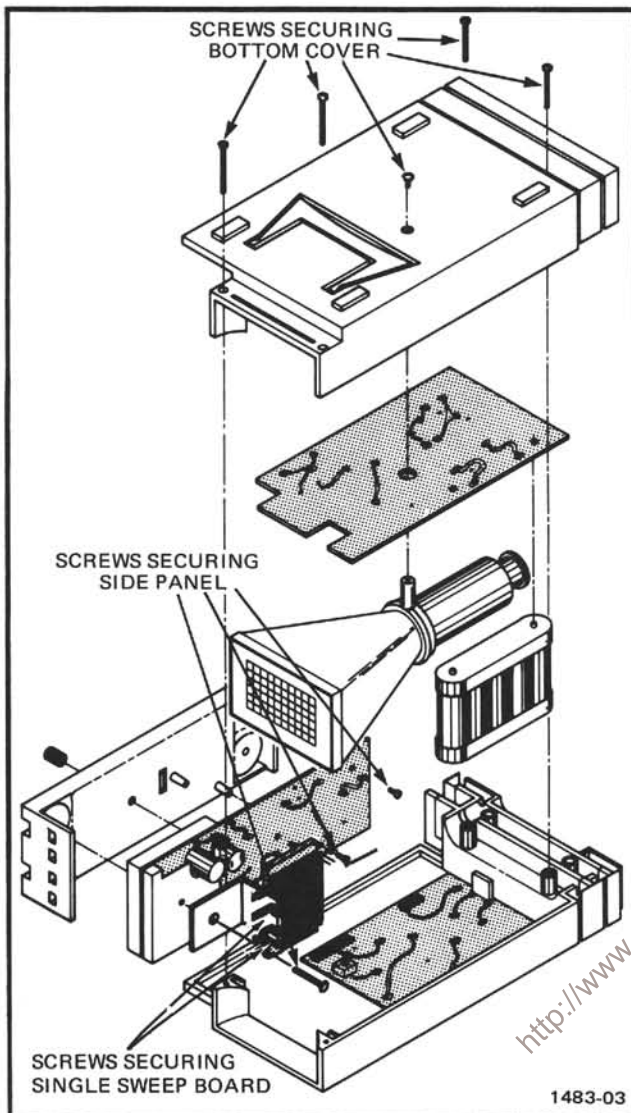

Fig. 3-2. Location of screws securing bottom cover, side panel, and Single Sweep board. (Instrument shown upside down.)

For calibration or troubleshooting within the 214, the Single Sweep (A-4) circuit board should be reconnected to the Power Supply (A-3) circuit board. This is done by first removing the front panel pushbuttons by pulling them, one at a time, until they disconnect from the Single Sweep (A-4) board. Next, remove the READY light from the front panel and the two screws securing the Single Sweep (A-4) board to the Input (A-1) circuit board. (See Fig. 3-2.) Then properly connect the Single Sweep circuit board to the Power Supply circuit board.

If access to the front of the Input (A-1) circuit board is necessary, remove the knobs from all the external control shafts. Remove the four screws securing the side panel to the Input circuit board and, with the READY light out of the front panel, remove the instrument side panel.

NOTE

Secure the Single Sweep board to the Input board and replace the front panel pushbuttons before re-assembling the instrument.

TROUBLESHOOTING

Introduction

The following information is provided to facilitate troubleshooting the 214. Information contained in other sections of this manual should be used along with the following information to aid in locating the defective component. An understanding of the circuit operation is very helpful in locating troubles. See the Circuit Description section for more information.

Troubleshooting Aids

Diagrams. Complete circuit diagrams are given on foldout pages in the Diagrams section. The component number and electrical value of each component in this instrument are shown on the diagrams (see first page of the Diagrams section for definition of the reference designators used to identify components in this instrument). Important voltages and waveforms are also shown on the diagrams. The portions of the circuit mounted on circuit boards are enclosed with blue lines.

Troubleshooting Equipment

The majority of troubleshooting to be done on the 214 can be accomplished with a 20,000 ohms/volt VOM such as a Triplet Model 630-NA or a Simpson Model 262. Use a dynamic transistor tester such as a Tektronix Type 577 Transistor-Curve Tracer to check the semiconductor devices used in the 214. To check waveforms in this instrument, use a test oscilloscope with a DC to 500 kilohertz frequency response and one millivolt to 50 volt/division deflection factor.

CORRECTIVE MAINTENANCE

Obtaining Replacement Parts

Standard Parts. All electrical and mechanical part replacements for the 214 can be obtained through your local Tektronix Field Office or representative. However, many of the standard electronic components can be obtained locally in less time than is required to order them from Tektronix, Inc. Before purchasing or ordering replacement parts, check the parts list for value, tolerance, rating, and description.

NOTE

When selecting replacement parts, it is important to remember that the physical size and shape of a component may affect its performance in the instrument. All replacement parts should be direct replacements unless it is known that a different component will not adversely affect the instrument performance.

Special Parts. In addition to the standard electronic components, some special components are used in the 214. These components are manufactured or selected by Tektronix, Inc. to meet specific performance requirements, or are manufactured for Tektronix, Inc. in accordance with our specifications. Most of the mechanical parts used in this instrument have been manufactured by Tektronix, Inc. Order all special parts directly from your local Tektronix Field Office or representative.

Ordering Parts. When ordering replacement parts from Tektronix, Inc., include the following information:

1. Instrument type.
2. Instrument serial number.
3. A description of the part (if electrical, include circuit number).
4. Tektronix Part Number.

WARNING

Disconnect the instrument from any external power source before replacing components.

Component Replacement

Circuit Board Replacement. If a circuit board is damaged beyond repair, the entire assembly including all soldered on components can be replaced. Part numbers are given in the Mechanical Parts List for the completely wired board.

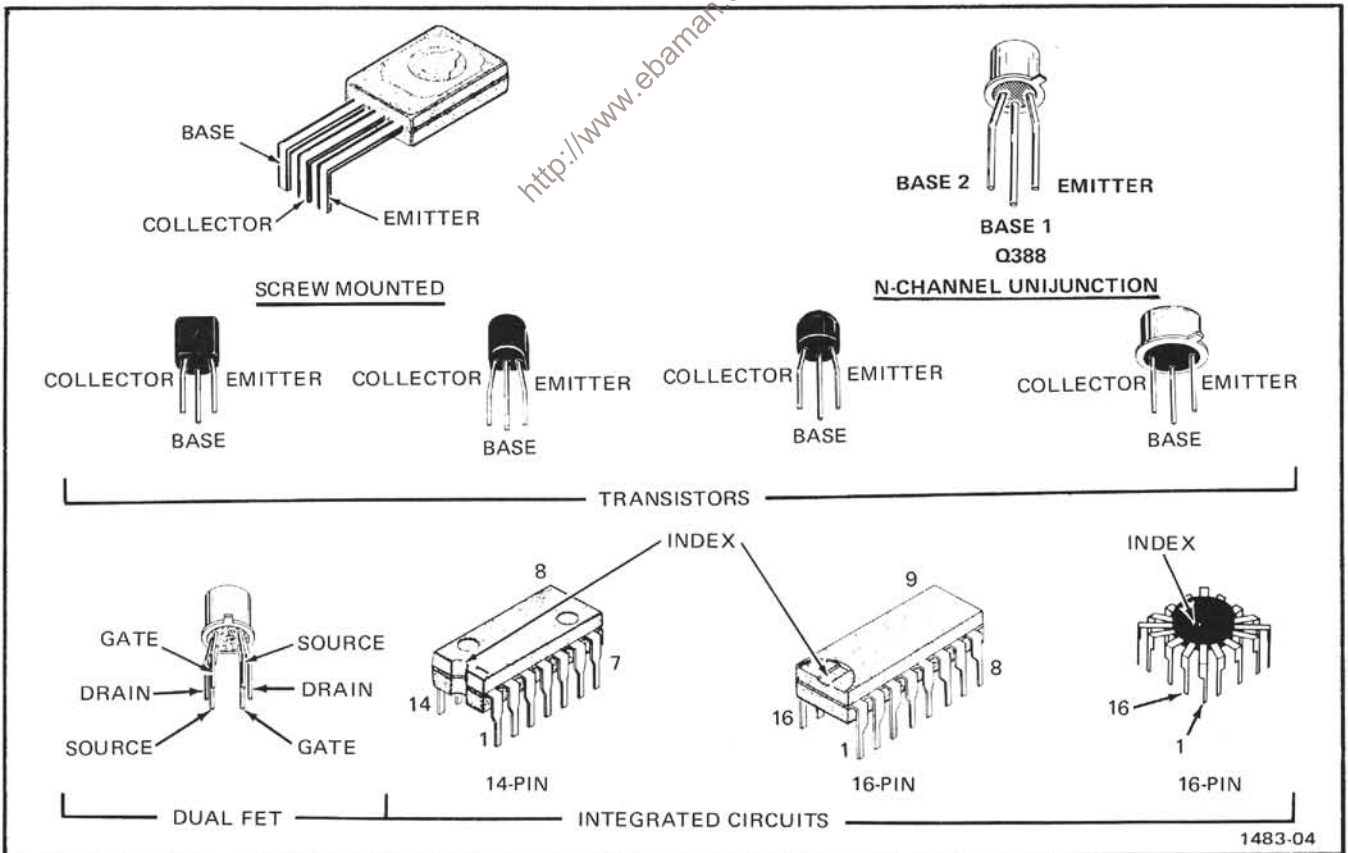

Fig. 3-3. Lead configurations of semiconductors used in this instrument.

Transistor Replacement. Transistors should not be replaced unless actually defective. If removed from their sockets during routine maintenance, return them to their original sockets. Unnecessary replacement of transistors may affect the calibration of this instrument. When transistors are replaced, check the operation of that part of the instrument which may be affected.

Replacement transistors should be of the original type or a direct replacement. Fig. 3-3 shows the lead configuration of the transistors used in this instrument. Some plastic case transistors have lead configurations which do not agree with those shown here. If a transistor is replaced by a transistor which is made by a different manufacturer than the original, check the manufacturer's basing diagram for correct basing. All transistor sockets in this instrument are wired for the basing used for metal-case transistors.

An extracting tool should be used to remove the 14- and 16-pin flat integrated circuits to prevent damage to the pins. If an extracting tool is not available when removing one of these integrated circuits, pull slowly and evenly on both ends of the device. Avoid having one end of the I.C. disengage from the socket before the other, as the pins may be damaged. When replacing semiconductors, key the semiconductor's index with that of the socket. Failure to do so will result in damaged components.

Rotary Switches. Individual parts of the VOLTS/DIV and SEC/DIV rotary switches are replaceable. Refer to the Parts List for the applicable part numbers for replacement parts.

Power Supply Capacitors. When operating the instrument from power sources other than 115 VAC 60 Hz, it is necessary to change the electrical value of capacitors C210 and C212 to maintain proper current levels to the batteries. Refer to Table 3-1 for the correct values of capacitance for three of the more commonly used line voltage/line frequency combinations.

TABLE 3-1
POWER SUPPLY CAPACITORS

Nominal Power Line Voltage/Frequency	Capacitor Values
	C210 - C212
110 to 126 VAC 58 to 62 Hz (Standard)	3.3 μ F, $\pm 10\%$, 200 VDC Tektronix PN 285-0925-00
90 to 110 VAC 48 to 52 Hz (Option 2)	4 μ F, $\pm 10\%$, 200 VDC Tektronix PN 285-0935-00
220 to 250 VAC 48 to 52 Hz (Option 1)	2 μ F, $\pm 10\%$, 400 VDC Tektronix PN 285-0933-00

CAUTION

Due to the capacitive power line circuit, sudden voltage changes may cause damaging current transients. Avoid operating this instrument from square-wave inverter supplies, or other sources that produce large voltage transients.

Selection of capacitor values for other line voltage/line frequency combinations is illustrated by the graphs in Figs. 3-4 and 3-5. For example, if the instrument is to be operated on a 60 Hz line, the graph in Fig. 3-5 illustrates the minimum and maximum line voltage limits, with respect to the 3.3 μ F capacitance values, for proper operation of the instrument. It also provides information for selecting values of C210 and C212 for other line voltages. Fig. 3-4 provides 50 Hz information. These capacitors should be selected from a type suitable for AC operation and voltage ratings should be at least 1.414 times the value of the applied line voltage.

C204 and C215 values must be changed from the nominal value only when the instrument is to be operated from other than 115V 50 Hz or 115V 60 Hz power line. For 240V 50 Hz operation, C204 and C215 should be replaced with .001 μ F 3kV capacitors.

Selectable Components. Resistor R388 value is selected for a switching unblanked trace height of no more than 1.5 divisions for each channel and minimum intensity change when changing sweep speeds from 5 ms to 2 ms. The value of R388 is selected from a range of 270, 300, or 330 Ω as follows:

1. Install a 270 Ω resistor for R388, turn the 214 on, set SEC/DIV to .5 s, and set INTENSITY to maximum (fully clockwise).
2. The traces will show as dots. Set CH 1 POS to place the CH 1 dot to the top horizontal graticule line and set CH 2 POS to place the CH 2 dot to the bottom horizontal graticule line.
3. Check that no more than 1.5 divisions of unblanked trace extends vertically from each dot.
4. If each unblanked trace exceeds 1.5 vertical divisions, turn off the 214, install the next larger size for R388, recheck and repeat steps 2 through 4 until unblanked traces are no more than 1.5 divisions high while maintaining minimum intensity change when switching sweep speed from 5 ms to 2 ms.

Recalibration After Repair

After any electrical component has been replaced, the calibration of that particular circuit should be checked, as well as the calibration of other closely related circuits. Since the power supply affects all circuits, calibration of the entire instrument should be checked if work has been done in the supply.

Instrument Repackaging

If the Tektronix instrument is to be shipped to a Tektronix Service Center for service or repair, attach a tag showing: owner (with address) and the name of an individual at your firm that can be contacted, complete instrument serial number and a description of the service required.

Save and re-use the package in which your instrument was shipped. If the original packaging is unfit for use or not available, repackage the instrument as follows:

Surround the instrument with polyethylene sheeting to protect the finish of the instrument. Obtain a carton of corrugated cardboard of the correct carton strength and having inside dimensions of no less than six inches more than the instrument dimensions. Cushion the instrument by tightly packing three inches of dunnage or urethane foam between carton and instrument, on all sides. Seal carton with shipping tape or industrial stapler.

The carton test strength for your instrument is 200 pounds.

<http://www.ebaman.com>

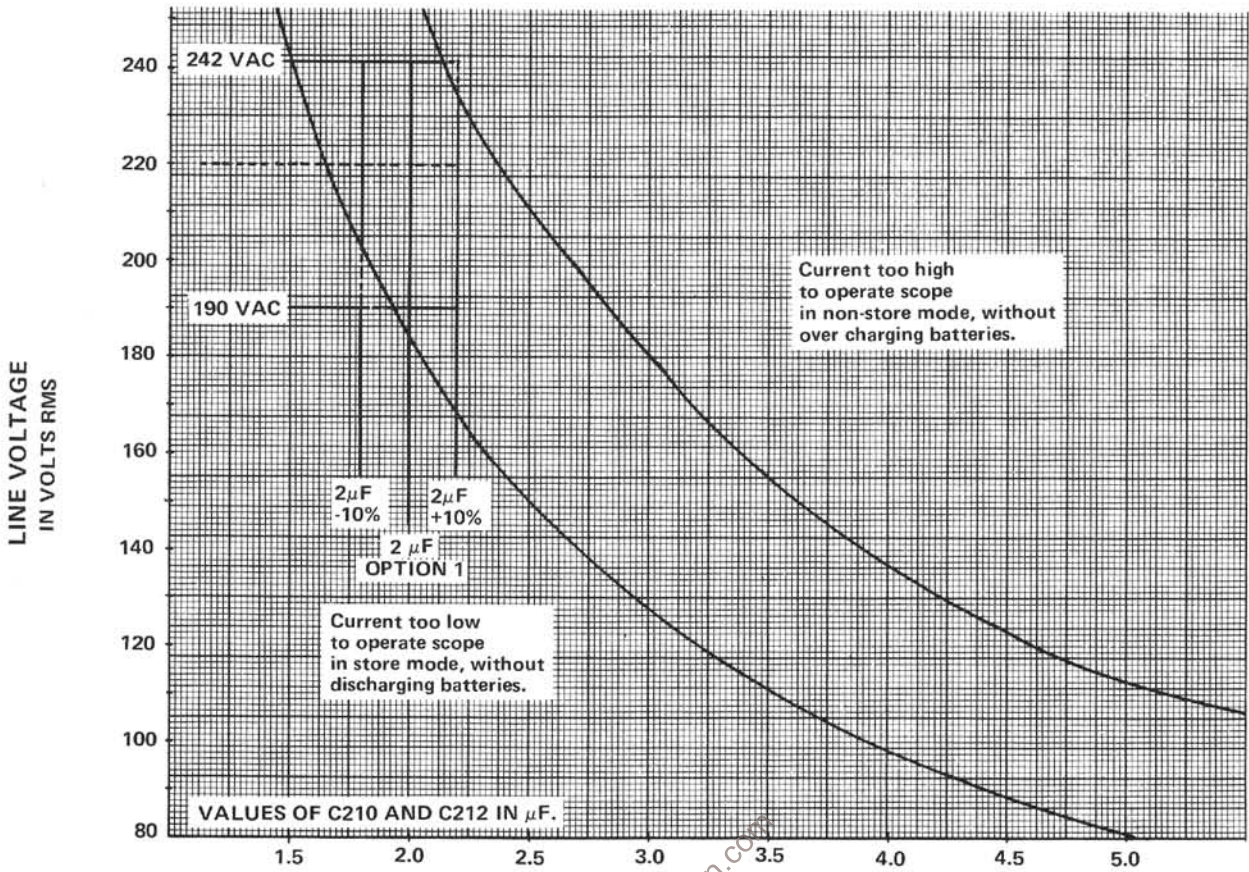

Fig. 3-4. Selecting power supply capacitors for 48 to 52 Hz sinewave operation.

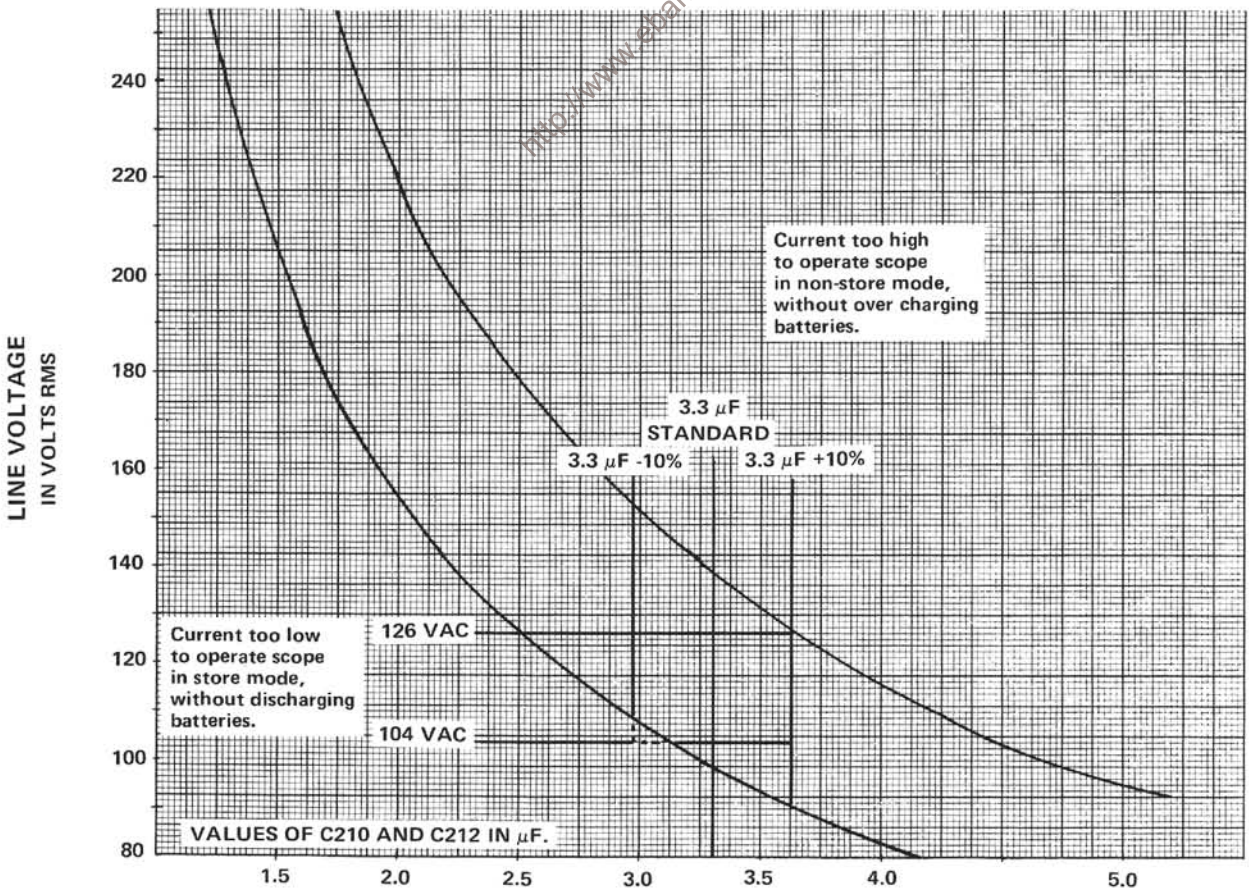

Fig. 3-5. Selecting power supply capacitors for 58 to 62 sinewave operation.

CALIBRATION

General

To ensure instrument accuracy, check the calibration of the 214 every 1000 hours of operation, or every six months if used infrequently. Before complete calibration, thoroughly clean and inspect this instrument as outlined in the Preventive Maintenance section.

Tektronix, Inc., provides complete instrument repair and recalibration at local Field Service Centers and the Factory Service Center. Contact your local Tektronix Field Office or representative for further information.

Completion of each step in the Calibration procedure ensures that this instrument meets the electrical specifications given in the INTRODUCTION of this manual. Where possible, instrument performance is checked before an adjustment is made. For best overall performance, make each adjustment to the exact setting even if the CHECK— step is within the allowable tolerances.

TEST EQUIPMENT REQUIRED

The following test equipment and accessories, or their equivalent, are required for complete calibration of the 214. Given specifications for the test equipment are the minimum necessary for accurate calibration. Therefore, the specifications of any test equipment must either meet or exceed those listed below. All test equipment is assumed to be correctly calibrated and operating within the listed specifications. Detailed operating instructions for the test units are not given in this procedure. Refer to the instruction manual for the test equipment if more information is needed.

Special Calibration Fixtures

Special Tektronix Calibration fixtures are used in this procedure only where they facilitate instrument calibration. These special calibration fixtures are available from Tektronix, Inc. Order by part number through your local Tektronix Field Office or representative.

TABLE 4-1

Test Equipment

Description	Minimum Specifications	Usage	Example
1. DC Voltmeter	Range, zero to 1000 volts; accuracy, within 3%; input impedance, 20,000 Ω /volt.	Power Supply output level checks, CRT Grid Bias, Storage Level adjustments. Vertical and horizontal centering adjustments.	a. Triplet Model 630-NA. b. Simpson Model 262.
2. Low-Frequency Constant-Amplitude Signal Generator	Frequency, one kilohertz to 500 kilohertz; output amplitude, at least 200 millivolts.	Storage Enhance Level adjustment. Vertical amplifier bandwidth and trigger operation checks.	a. General Radio 1310-B Oscillator.
3. Standard Amplitude Calibrator	Amplitude accuracy, 0.25%; signal amplitude, five millivolts to 100 volts; output signal, one-kilohertz square wave.	Vertical and horizontal gain checks and adjustments.	a. Tektronix Part No. 067-0502-01.

TABLE 4-1 (cont)

Description	Minimum Specifications	Usage	Example
4. Square-Wave Generator	Frequency, one kilohertz; risetime, 100 nanoseconds or less; output amplitude, 0.4 volt to 40 volts.	Vertical amplifier compensation checks and adjustments.	a. Tektronix Type 106 Square-Wave Generator.
5. Time-Mark Generator	Marker outputs, five microseconds to 0.1 second; marker accuracy, within 0.1%.	Horizontal timing checks and adjustment.	a. Tektronix Type 2901 Time-Mark Generator. b. Tektronix Type 183 Time-Mark Generator.
6. Ramp Generator	Frequency, at least 100 microseconds; output amplitude, at least six volts; external triggering, both AUTO and NORMAL.	Hum Balance adjustment.	a. Tektronix Type RG 501 Ramp Generator with Type TM 501 Power Supply.
7. Attenuator	Ratio, 10X; connectors, BNC; impedance, 50 Ω.	Storage Enhance Level adjustment. Vertical amplifier bandwidth check.	a. Tektronix Part No. 011-0059-02.
8. Cable	Impedance, 50 Ω; type RG-58/U; length, 42 inches; connectors, BNC.	External trigger operation check.	a. Tektronix Part No. 012-0057-01.
9. Adapter	Connectors, GR874 and BNC female.	Vertical amplifier compensation checks and adjustments.	a. Tektronix Part No. 017-0063-00.
10. Adapter	Connectors, probe tip-to-BNC.	Used throughout procedure for signal interconnection.	a. Tektronix Part No. 013-0084-01.
11. Adapter	Connectors, BNC female-to-banana plug.	External trigger checks.	a. Tektronix Part No. 103-0090-00.
12. Termination	Impedance, 50 Ω; accuracy, 2%; connectors, BNC.	Vertical amplifier compensation checks and adjustments.	a. Tektronix Part No. 011-0049-01.
13. T-Connector	Connectors, BNC.	External trigger checks.	a. Tektronix Part No. 103-0030-00.
14. Screwdriver	Three-inch shaft; 3/32 inch bit.	Used throughout procedure to adjust variable resistors.	a. Xcelite R-3323
15. Low-Capacitance Screwdriver	1 1/2-inch shaft.	Used to adjust variable capacitors.	a. Tektronix Part No. 003-0000-00.

PRELIMINARY PROCEDURE

This instrument should be adjusted at an ambient temperature of +25°C (±5°C) for best overall accuracy.

1. Remove the instrument covers as described in the Disassembly Instructions in the Preventive Maintenance section.

2. Connect the instrument to a 117 VAC, 60 Hz line source. If the batteries are not fully charged, leave the 214 connected to the line with the power switch turned OFF for a period of approximately one hour before continuing with calibration.

3. Set the instrument controls as given under Preliminary Control Settings. Allow at least five minutes of warmup before proceeding.

NOTE

Titles for external controls of this instrument are fully capitalized in this procedure (e.g., SINGLE SWP). Internal adjustments are initial capitalized only (e.g., Grid Bias).

PRELIMINARY CONTROL SETTINGS

Preset the instrument controls to the settings given below when starting calibration.

Single Sweep Controls

SINGLE SWP	Out
RESET	Out

Storage Controls

STORE	Out (NONSTORE mode)
ERASE	Out

Channel 1 Controls

VOLTS/DIV	5 m
VAR VOLTS/DIV	CAL (detent)
POS	Midrange
INPUT COUPLING	GND

Channel 2 Controls

VOLTS/DIV	5 m
VAR VOLTS/DIV	CAL (detent)
POS	OFF (detent)
INPUT COUPLING	GND

Trigger Controls

TRIG SOURCE	COMP
LEVEL/SLOPE	AUTO PRESET (detent)

Sweep Controls

SEC/DIV	1 m
VAR HORIZ MAG	CAL (detent)
POS	Midrange

Display Controls

POWER	ON
INTENSITY	Fully counterclockwise

POWER SUPPLY AND DISPLAY

Equipment Required

- | | |
|--|-----------------------------|
| 1. Ramp Generator (TM 501/RG 501) | 4. Probe tip-to-BNC Adapter |
| 2. DC Voltmeter | 5. 10X BNC Attenuator |
| 3. Low-Frequency Constant-Amplitude Signal Generator (General Radio 1310-B Oscillator) | 6. Three-inch Screwdriver |

Control Settings

Preset instrument controls to the settings given under Preliminary Control Settings.

TABLE 4-2

Power Supply Accuracy

Supply	Measurement
-5.6 V	-5.6 volts \pm 0.4 volt
+5.6 V	+5.6 volts \pm 0.4 volt
+65 V	+65 volts \pm 4 volts
-1000 V	-960 volts \pm 40 volts (due to meter loading)

1. Check Power Supply DC Levels

NOTE

If the instrument has been operating satisfactorily prior to recalibration, proceed with step 2.

a. Using the DC Voltmeter, measure the DC level of the power supplies given in Table 4-2. Observe proper meter polarity. See Fig. 4-1 for test point locations.

b. To measure the -100 V supply:

1. Depress the STORE button.
2. Measure the -100V supply for a reading of -95 volts to -110 volts (see Fig. 4-2).
3. Press the STORE button to release it.

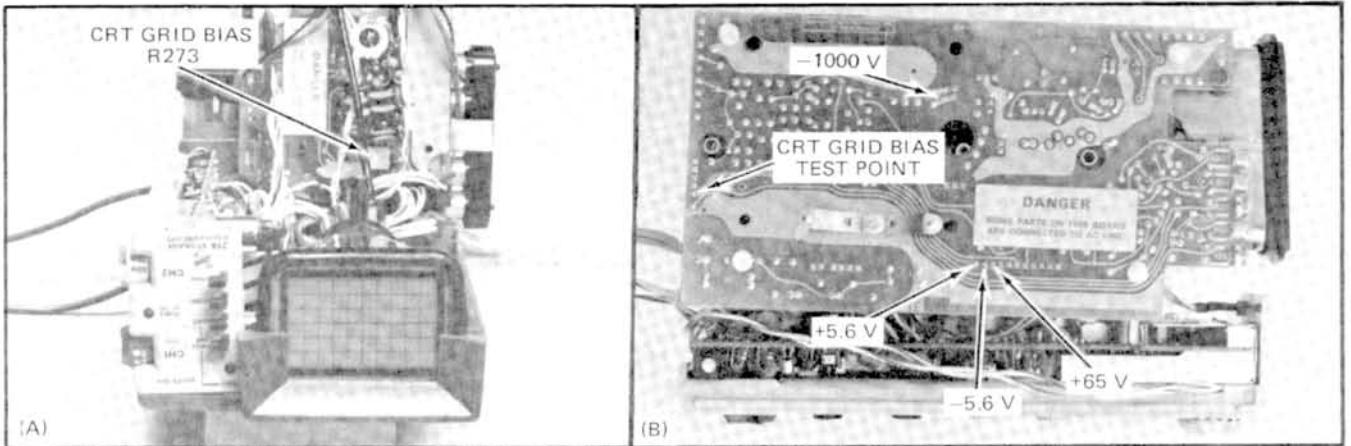

Fig. 4-1. (A) Location of Grid Bias adjustment and (B) Power supply test points.

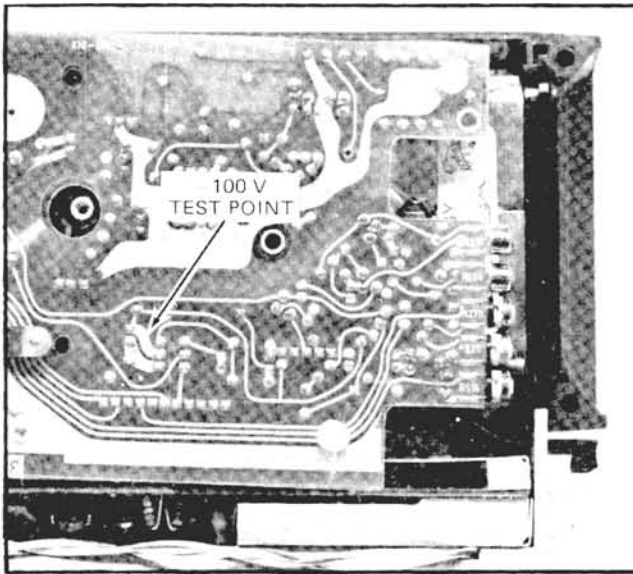

Fig. 4-2. Location of -100 V test point.

2. Adjust CRT Grid Bias

a. Connect the DC Voltmeter between pin 5 and pin 2 of plug P3 (negative meter lead to pin 2) on the Power Supply Board (A-3). See Fig. 4-1.

b. Turn the INTENSITY control fully clockwise.

c. CHECK—Meter reading of +1.9 volts.

d. ADJUST—CRT Grid Bias adjustment, R273, for a meter reading of +1.9 volts.

e. Disconnect meter leads. Turn the INTENSITY control fully counterclockwise.

3. Adjust FOCUS

a. Turn the CH 2 POS control to midrange and the CH 1 POS control to the OFF detent.

b. Set the SEC/DIV switch to X-Y and adjust the INTENSITY control for a nominal display intensity.

c. ADJUST—FOCUS, R398 (located on the 214 side panel) for a well-defined dot.

4. Adjust Trace Rotation

a. Set the SEC/DIV switch to 1 m.

b. Position the trace to the center horizontal graticule line.

c. CHECK—Free-running sweep is parallel with the horizontal graticule line.

d. ADJUST—Trace Rotation adjustment, R141 (see Fig. 4-3) to align the sweep with the center horizontal graticule line.

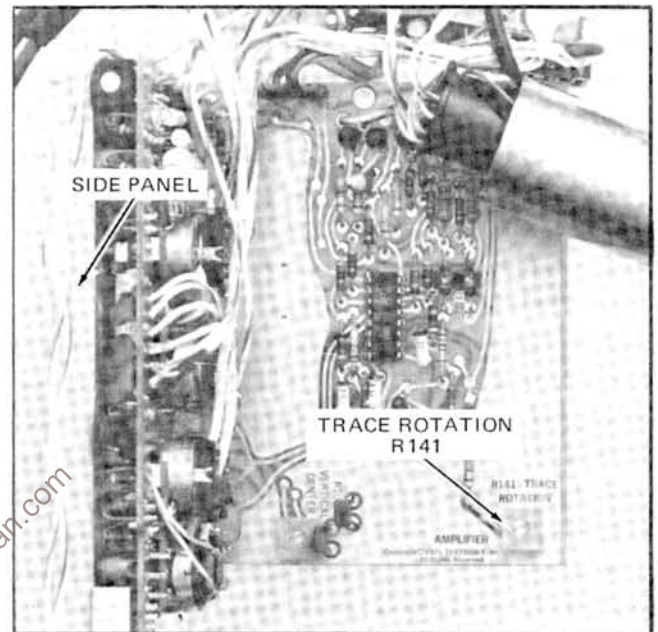

Fig. 4-3. Location of Trace Rotation adjustment.

5. Adjust Storage Operating Level

a. Determine the upper writing limit of the CRT.

(1) Turn the CH 1 POS control to midrange and vertically position the two traces within the center four graticule divisions.

(2) Set the SEC/DIV switch to 5 m and turn the INTENSITY control fully clockwise.

(3) PRESET—Operating Level adjustment, R510 (see Fig. 4-4) fully counterclockwise.

(4) Connect the DC Voltmeter between pin 4 of plug 22 and ground (negative meter lead to ground) on the Power Supply (A-3) board. See Fig. 4-4.

(5) Depress the SINGLE SWP button and the STORE button.

(6) Press the ERASE button.

(7) Press the RESET button.

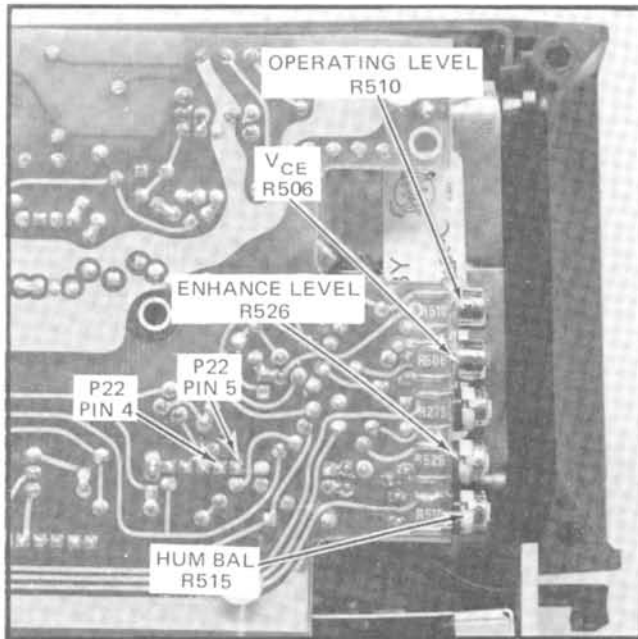

Fig. 4-4. Location of storage operation adjustments.

(8) Adjust the LEVEL/SLOPE control for a triggered sweep.

(9) ADJUST—If the traces thicken or begin to flood the CRT during the first minute after Storage, reduce the Operating Level, R510, a small amount clockwise.

(10) Repeat steps 5-a-6 through 5-a-9 until the traces no longer flood or thicken during the first minute after Storage.

(11) CHECK—Reading on the DC Voltmeter. Record this reading for use in step 5-c.

b. Determine the writing threshold of the CRT.

(1) Turn the INTENSITY control for the minimum Stored trace intensity.

(2) Press the ERASE button.

(3) Press the RESET button.

(4) Adjust the LEVEL/SLOPE control for a triggered sweep

(5) CHECK—For Stored traces with no breaks in the display during the first minute of storage.

(6) ADJUST—If breaks occur in the Stored traces during the first minute of Storage, increase the Operating Level, R510, a small amount counterclockwise.

(7) Repeat step 5-b-2 through 5-b-6 until no breaks occur in the display during the first minute of Storage.

(8) CHECK—Reading on the DC Voltmeter. Record this reading for use in step 5-c.

c. Subtract the voltage reading of step 5-b-8 from the reading obtained in step 5-a-11. Add one-half of the difference to the reading taken in step 5-b-8. For example:

First Reading		58 volts
Second Reading	—	28 volts
Difference	=	30 volts

$$\text{Second Reading} + \frac{\text{Difference}}{2} = \text{Operating Level}$$

Operating Level for the example would be 43 volts.

d. ADJUST—Operating Level adjustment, R510, for a reading on the DC Voltmeter equal to the voltage calculated in step 5-c.

NOTE

If the first reading, step 5-a-11, is greater than +55 volts, and the second reading, step 5-b-8, is less than +35 volts, adjust R510 for a meter reading of +45 volts.

e. Remove the meter lead connections.

6. Adjust Wall Band Level

a. Connect the DC Voltmeter between pin 5 of plug 22 and ground (positive meter lead to ground) on the Power Supply (A-3) board. See Fig. 4-4.

b. Rotate V_{CE} adjustment, R506 (see Fig. 4-4), from fully clockwise to fully counterclockwise.

c. CHECK—For a range of at least -40 V to 0 V while rotating the V_{CE} adjustment.

d. Press and hold down the ERASE button.

e. ADJUST— V_{CE} adjustment, R506, until the illuminated part of the display covers the entire CRT screen with equal brightness at the center and edges of the screen.

- f. Release the ERASE button.
- g. CHECK—For uniform erasure of the CRT screen.
- h. Release STORE and SINGLE SWP buttons.

7. Adjust Enhance Level

- a. Set the SEC/DIV switch to 5μ , the TRIG SOURCE switch to CH 2, the CH 2 INPUT COUPLING switch to AC, the INTENSITY control for a visible display, and turn the CH 1 POS control to the OFF detent.
- b. Connect the CH 2 probe tip to the output of the Low-Frequency Constant-Amplitude Signal Generator via a X10 BNC attenuator and a probe tip-to-BNC adapter.
- c. Adjust the Low-Frequency Constant-Amplitude Signal Generator for a 3.2-division display of a 50 kHz signal.
- d. Depress the SINGLE SWP and STORE buttons.
- e. Press the ERASE button. Wait 5 seconds.
- f. Press the RESET button.
- g. ADJUST—Enhance Level adjustment, R526 (see Fig. 4-4) for the best possible display.
- h. Press the RESET button several times in succession.
- i. CHECK—Entire CRT screen may be flooded positive.
- j. Disconnect the test setup.

8. Adjust the Hum Balance

- a. Set the SEC/DIV switch to X-Y and the CH 2 VOLTS/DIV switch to 2.

- b. Connect the CH 2 probe tip to the Ramp output of the Ramp Generator.
- c. Set the Ramp Generator for External Auto Triggering and a six-volt, $100\mu\text{s}$, ramp output.
- d. Using the CH 2 and horizontal POS controls, position the display to write the entire CRT screen.
- e. Center the display on the CRT graticule.
- f. Set the Ramp Generator for Normal Triggering.
- g. Connect a X1 probe from the External Input jack of the Ramp Generator to the test point shown in Fig. 4-5.
- h. Adjust the Ramp Generator Triggering controls for a stable display.
- i. ADJUST—Hum Bal adjustment, R515, for minimum horizontal deflection.

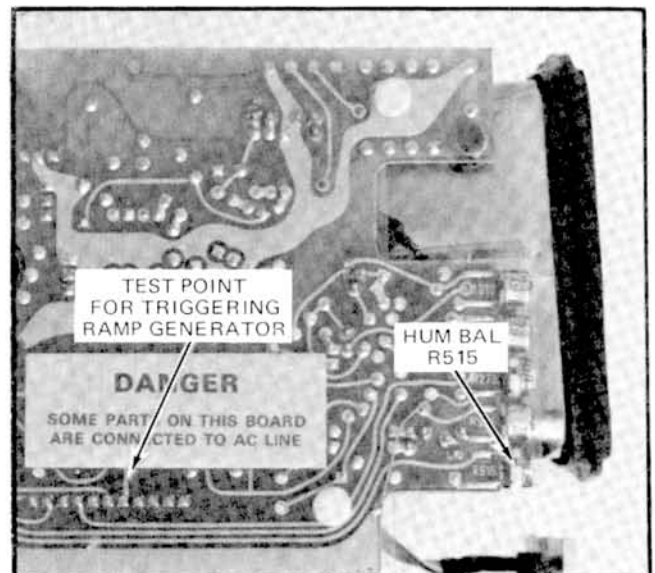

Fig. 4-5. Location of Hum Balance adjustment, and external trigger test point for ramp generator.

VERTICAL SYSTEM

Equipment Required

- | | |
|---|--|
| <ol style="list-style-type: none"> 1. DC Voltmeter 2. Low-Frequency Constant-Amplitude Signal Generator (General Radio 1310-B Oscillator) 3. Standard Amplitude Calibrator (067-0502-01) 4. Square-Wave Generator (Type 106) 5. Probe tip-to-BNC Adapter | <ol style="list-style-type: none"> 6. GR-to-BNC Adapter 7. 10X BNC Attenuator 8. 50 Ω BNC Termination 9. Three-inch Screwdriver 10. Low-capacitance Screwdriver |
|---|--|

Control Settings

Preset instrument controls to the settings given under Preliminary Control Settings, except as follows:

INTENSITY Visible Display

9. Adjust Vertical DC Centering

- a. Connect the DC Voltmeter between pin 11 of U105, on the Amplifier (A-2) board, (positive meter lead to pin 11) and ground. See Fig. 4-6.
- b. Adjust the CH 1 POS control for a 0 volt reading on the meter.

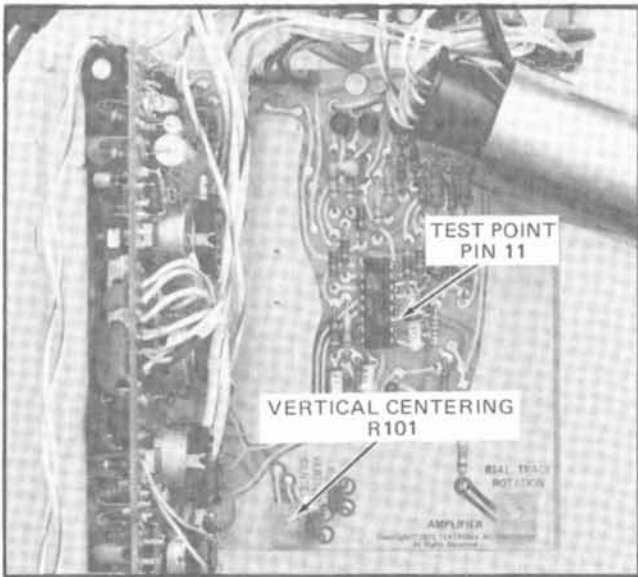

Fig. 4-6. Location of Vertical Centering adjustment and test point.

- c. CHECK—Trace should be within approximately 0.4 division of graticule center.
- d. ADJUST—Vertical Centering, R101 (see Fig. 4-6) to position the trace to the center horizontal graticule line.
- e. Disconnect the meter leads.

10. Adjust Channel 1 Step Attenuator Balance

- a. Rotate the CH 1 VOLTS/DIV switch from 50 m to 1 m.
- b. CHECK—The CRT display for 0.1 division, or less, of vertical trace shift between adjacent switch positions from 50 m to 1 m.
- c. ADJUST—CH 1 STEP ATTEN BAL, R417 (located on the side panel) for minimum trace shift when rotating the CH 1 VOLTS/DIV switch from 50 m to 1 m.

11. Adjust Channel 2 Step Attenuator Balance

- a. Turn the CH 1 POS control to OFF and the CH 2 POS control to midrange.
- b. Rotate the CH 2 VOLTS/DIV switch from 50 m to 1 m.
- c. CHECK—The CRT display for 0.1 division, or less, of vertical trace shift between adjacent switch positions from 50 m to 1 m.
- d. ADJUST—CH 2 STEP ATTEN BAL, R315 (located on the side panel) for minimum trace shift when rotating the CH 2 VOLTS/DIV switch from 50 m to 1 m.

12. Adjust Vertical Gain

- a. Set the CH 2 VOLTS/DIV switch to 5 m and the CH 2 INPUT COUPLING switch to DC.
- b. Connect the CH 2 probe tip to the output of the Standard Amplitude Calibrator via a probe tip-to-BNC adapter.
- c. Set the Standard Amplitude Calibrator for a 20-mV signal.
- d. CHECK—The CRT display for four divisions of deflection, within 0.2 division.
- e. ADJUST—VERT GAIN, R470 (located on the side panel) for exactly four divisions of deflection.

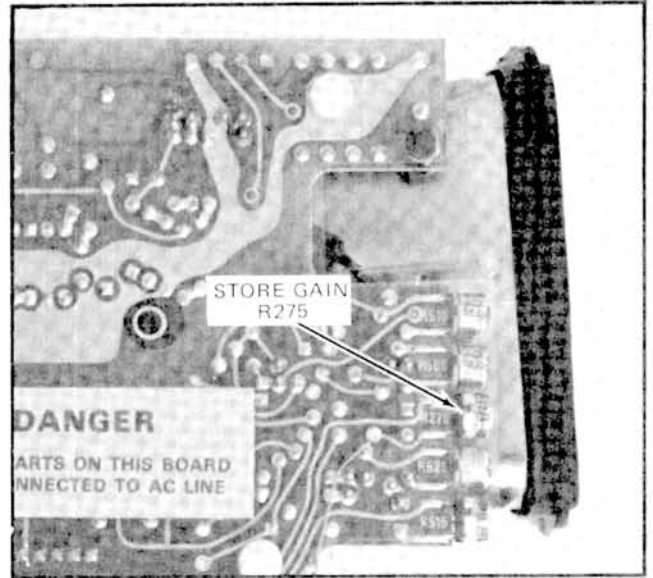

Fig. 4-7. Location of Store Gain adjustment.

13. Adjust Storage Vertical Gain

- a. Depress the SINGLE SWP and STORE buttons.
- b. Press the ERASE button.
- c. Press the RESET button.
- d. Adjust the LEVEL/SLOPE control for a triggered display.
- e. CHECK—CRT display for four divisions of deflection, within 0.2 divisions.
- f. ADJUST—Store Gain adjustment, R275 (see Fig. 4-7) for exactly four divisions of deflection.
- g. Repeat steps 13-b through 13-f until exactly four divisions of deflection are achieved.
- h. Release the STORE and SINGLE SWP buttons.

14. Check Channel 2 Variable Volts/Division Range

- a. Rotate the CH 2 VAR VOLTS/DIV control fully clockwise.
- b. CHECK—The CRT display for no more than 1.6 divisions of deflection. (1.6 divisions of deflection indicates a range of at least 2.5:1.)
- c. Return the CH 2 VAR VOLTS/DIV control to CAL.

15. Check Channel 2 Volts/Division Accuracy

- a. CHECK—Using the CH 2 VOLTS/DIV switch and Standard Amplitude Calibrator settings given in Table 4-3, check that the deflection factor accuracy for CH 2 is within 5% at each position.

TABLE 4-3

Vertical Deflection Accuracy

VOLTS/DIV Switch Setting	Standard Amplitude Calibrator Output	Vertical Deflection in Divisions	Maximum Error For ±5% Accuracy
1 m	5 millivolts	5	±0.25 division
2 m	10 millivolts	5	±0.25 division
5 m	20 millivolts	4	Previously set in Step 12
10 m	50 millivolts	5	±0.25 division
20 m	0.1 volt	5	±0.25 division
50 m	0.2 volt	4	±0.2 division
.1	0.5 volt	5	±0.25 division
.2	1 volt	5	±0.25 division
.5	2 volts	4	±0.2 division
1	5 volts	5	±0.25 division
2	10 volts	5	±0.25 division
5	20 volts	4	±0.2 division
10	50 volts	5	±0.25 division
20	100 volts	5	±0.25 division
50	100 volts	2	±0.1 division

16. Check Input Coupling Switches

a. Set both INPUT COUPLING switches to DC and both VOLTS/DIV switches to 10 m.

b. Adjust the Standard Amplitude Calibrator for a 20-mV output.

c. Position the bottom of the display to the center horizontal graticule line.

d. Set CH 2 INPUT COUPLING switch to GND.

e. CHECK—For no vertical deflection; trace is at the center horizontal graticule line.

f. Set CH 2 INPUT COUPLING switch to AC.

g. CHECK—That the display is centered about the center horizontal graticule line.

h. Remove the CH 2 probe tip from the Standard Amplitude Calibrator.

i. Turn the CH 2 POS control to OFF and the CH 1 POS control to midrange.

j. Connect the CH 1 probe tip to the output of the Standard Amplitude Calibrator via a probe tip-to-BNC adapter.

k. Position the bottom of the display to the center horizontal graticule line.

l. Set CH 1 INPUT COUPLING switch to GND.

m. Repeat step 16-e.

n. Set CH 1 INPUT COUPLING switch to AC.

o. Repeat step 16-g.

17. Check CH 1 Volts/Division Accuracy and Variable Volts/Division Range

a. Set the CH 1 INPUT COUPLING switch to DC.

b. CHECK—Using the CH 1 VOLTS/DIV switch and Standard Amplitude Calibrator settings given in Table 4-3, check that the deflection factor accuracy of CH 1 is within 5% at each position.

c. Set the Standard Amplitude Calibrator for a 20-mV output.

d. Set the CH 1 VOLTS/DIV switch to 5 m.

e. Rotate the CH 1 VAR VOLTS/DIV control fully clockwise.

f. CHECK—The CRT display for no more than 1.6 divisions of deflection.

g. Return the CH 1 VAR VOLTS/DIV control to CAL.

h. Disconnect the test setup.

18. Adjust Channel 1 VOLTS/DIV Compensation

a. Set the CH 1 VOLTS/DIV switch to .1 V.

b. Connect the CH 1 probe tip to the high amplitude output of the Type 106 Square-Wave Generator via a GR-to-BNC adapter, a 50 Ω BNC termination, and a probe tip-to-BNC adapter.

c. Adjust the Square-Wave Generator for a four-division display of a 1-kHz square wave.

d. Adjust the Triggering controls for a stable display.

e. CHECK—The CRT display for flat-top waveform with no more than +0.2 division, -0.1 division, or a total of 0.2 division of aberrations.

NOTE

If C307, C308, C309, C407, C408, or C409 require adjustment, it will be necessary to remove the instrument side panel from the Input Board (A-1). Refer to the Disassembly Instructions for removal procedure.

f. ADJUST—C407 (see Fig. 4-8) with a low-capacitance screwdriver, for no more than +0.2 division, -0.1 division, or a total of 0.2 division of aberration.

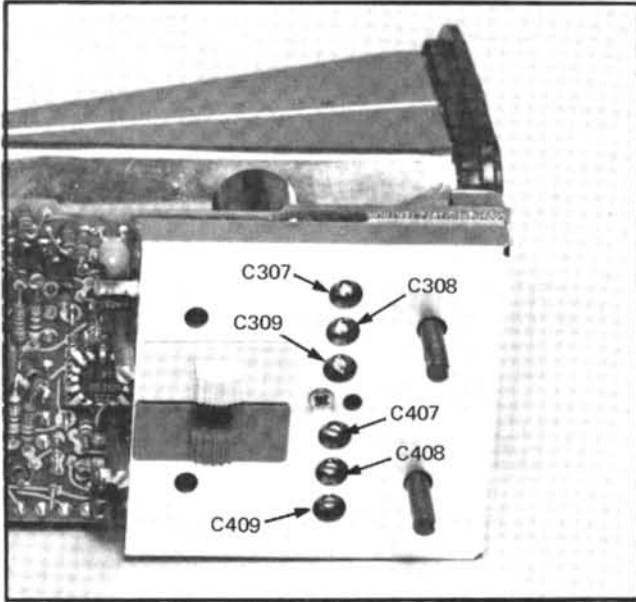

Fig. 4-8. Location of attenuator compensation capacitors.

g. Set the CH 1 VOLTS/DIV switch to 1 V and adjust the Square-Wave Generator for a four-division display.

h. CHECK—The CRT display for flat-top waveform with no more than +0.2 division, -0.1 division, or a total of 0.2 division of aberration.

i. ADJUST—C408 (see Fig. 4-8) for no more than +0.2 division, -0.1 division, or a total of 0.2 division of aberration.

j. Set the VOLTS/DIV switch to 10 V, remove the 50 Ω BNC termination from the test setup, and adjust the Square-Wave Generator for a four-division display.

k. CHECK—The CRT display for a flat-top waveform with no more than +0.2 division, -0.1 division, or a total of 0.2 division of aberration.

l. ADJUST—C409 (see Fig. 4-8) for no more than +0.2 division, -0.1 division, or a total of 0.2 division of aberration.

m. Disconnect the CH 1 probe tip from the test setup.

19. Adjust Channel 2 VOLTS/DIV Compensation

a. Turn the CH 1 POS control to OFF and the CH 2 POS control to midrange.

b. Set the CH 2 VOLTS/DIV switch to .1 V and the INPUT COUPLING switch to DC.

c. Connect the CH 2 probe tip to the high amplitude output of the Type 106 Square-Wave Generator via a GR-to-BNC adapter, a 50 Ω BNC termination, and a probe tip-to-BNC adapter.

d. Adjust the Square-Wave Generator for a four-division display of a 1-kHz square wave.

e. CHECK—The CRT display for flat-top waveform with no more than +0.2 division, -0.1 division, or a total of 0.2 division of aberration.

f. ADJUST—C307 (see Fig. 4-8) for no more than +0.2 division, -0.1 division, or a total of 0.2 division of aberration.

g. Set the CH 2 VOLTS/DIV switch to 1 V and adjust the Square-Wave Generator for a four-division display.

h. CHECK—The CRT display for a flat-top waveform with no more than +0.2 division, -0.1 division, or a total of 0.2 division of aberration.

i. ADJUST—C308 (see Fig. 4-8) for no more than +0.2 division, -0.1 division, or a total of 0.2 division of aberration.

j. Set the CH 2 VOLTS/DIV switch to 10 V, remove the 50 Ω BNC termination from the test setup, and adjust the Square-Wave Generator for a four-division display.

k. CHECK—The CRT display for a flat-top waveform with no more than +0.2 division, -0.1 division, or a total of 0.2 division of aberration.

l. ADJUST—C309 (see Fig. 4-8) for no more than +0.2 division, -0.1 division, or a total of 0.2 division of aberration.

m. Disconnect all test equipment, and replace the instrument side panel and knobs.

20. Check Vertical Amplifier Bandwidth

- a. Set the CH 2 VOLTS/DIV switch to 1 m.
- b. Connect the CH 2 probe tip to the output of the Low-Frequency Constant-Amplitude Signal Generator via a X10 BNC attenuator and a probe tip-to-BNC adapter.
- c. Adjust the Signal Generator for a six-division display of a 1-kHz signal.
- d. Without adjusting the output amplitude, increase the output frequency of the Signal Generator until the display is reduced in amplitude to 4.2 divisions.
- e. CHECK—The Signal Generator output frequency must be at least 100 kHz.
- f. Set the VOLTS/DIV switch to 2 mV and adjust the Signal Generator for a six-division display of a 1-kHz signal.
- g. Repeat step 20-d.
- h. CHECK—The Signal Generator output frequency must be at least 200 kHz.
- i. Set the VOLTS/DIV switch to 5 m and adjust the Signal Generator for a six-division display of a 1-kHz signal.
- j. Repeat step 20-d.
- k. CHECK—The Signal Generator output frequency must be at least 400 kHz.
- l. Set the VOLTS/DIV switch to 10 m and adjust the Signal Generator for a six-division display of a 1-kHz signal.
- m. Repeat step 20-d.
- n. CHECK—The Signal Generator output frequency must be at least 500 kHz.
- o. Disconnect the CH 2 probe tip from the test setup.
- p. Connect the CH 1 probe tip to the test setup.
- q. Turn the CH 2 POS control to OFF and the CH 1 POS control to midrange.
- r. Set the CH 1 VOLTS/DIV switch to 1 m.
- s. Repeat step 20-c through 20-n.

TRIGGER CIRCUIT

Equipment Required

- | | |
|--|-------------------------------|
| 1. Low-Frequency Constant-Amplitude Signal Generator (General Radio 1310-B Oscillator) | 4. BNC-T Connector |
| 2. 42-inch 50 Ω BNC Cable | 5. BNC-to-Banana Plug Adapter |
| 3. Probe tip-to-BNC Cable | 6. Three-inch Screwdriver |

Control Settings

Preset instrument controls to the settings given under Preliminary Control Settings except as follows:

INTENSITY	Visible Display
SEC/DIV	1.0 m
CH 1 INPUT COUPLING	DC
CH 1 POS	OFF
CH 2 POS	Midrange
TRIG SOURCE	CH 2

21. Adjust AUTO PRESET Level

a. Connect the CH 2 probe tip to the output of the Low-Frequency Signal Generator (General Radio 1310-B Oscillator) via a BNC-T connector and a probe tip-to-BNC adapter.

b. Adjust the Low-Frequency Signal Generator for a 0.2-division display of a 5-kHz signal.

c. CHECK—For a stable display.

d. ADJUST—AUTO PRESET, R375 (located on the side panel) for a stable display.

22. Check Trigger Circuit Operation

a. Set the CH 2 VOLTS/DIV switch to 1 V.

b. Adjust the Low-Frequency Signal Generator for a 1-division display of a 500-kHz signal.

c. Set the CH 2 VOLTS/DIV switch to 5 V.

d. CHECK—A stable display can be obtained by adjusting the LEVEL/SLOPE control to trigger on both the positive-going and negative-going slopes of the displayed waveform.

e. Return the LEVEL/SLOPE control to the AUTO PRESET detent.

f. Set the TRIG SOURCE switch to COMP.

g. CHECK—A stable display can be obtained by adjusting the LEVEL/SLOPE control to trigger on both the positive-going and negative-going slopes of the displayed waveform.

h. Set the TRIG SOURCE switch to EXT and the LEVEL/SLOPE control to the AUTO PRESET detent.

i. Connect the unused output of the BNC-T connector to the 214 EXT TRIG input via a 42-inch 50 Ω BNC cable and a BNC-to-banana plug adapter.

j. CHECK—A stable display can be obtained by adjusting the LEVEL/SLOPE control to trigger on both the positive-going and negative-going slopes of the displayed waveform.

23. Check Single Sweep Operation

a. Adjust the LEVEL/SLOPE control for a triggered display.

b. Disconnect the CH 2 probe tip from the signal source.

c. Depress the SINGLE SWP button.

d. Press the RESET button.

e. CHECK—READY light comes on when RESET button is pressed and remains on until the CH 2 probe tip is re-applied to the signal source.

Calibration—214 Service

f. Reconnect the CH 2 probe tip to the Low-Frequency Signal Generator.

h. Press the RESET button.

g. CHECK—READY light is extinguished.

i. CHECK—That a single-sweep display (one sweep only) is presented.

<http://www.ebaman.com>

HORIZONTAL SYSTEM

Equipment Required

- | | |
|---|--|
| <ol style="list-style-type: none"> 1. DC Voltmeter 2. Standard Amplitude Calibrator (067-0502-01) | <ol style="list-style-type: none"> 3. Probe tip-to-BNC Adapter 4. Time-Mark Generator (Type 2901) 5. Three-inch Screwdriver |
|---|--|

Control Settings

Preset instrument controls to the settings given under Preliminary Control Settings except as follows:

INTENSITY	Visible Display
SEC/DIV	X-Y
CH 2 POS	Midrange

24. Adjust Horizontal Centering

a. Connect the DC Voltmeter between pin 5 of U105, on the Amplifier (A-2) board, (positive meter lead to pin 5) and ground. See Fig. 4-9.

b. CHECK—For a reading of 0 volts, ± 0.2 volt.

c. ADJUST—Horiz. Center, R366, for a meter reading of 0 volts, ± 0.2 volt.

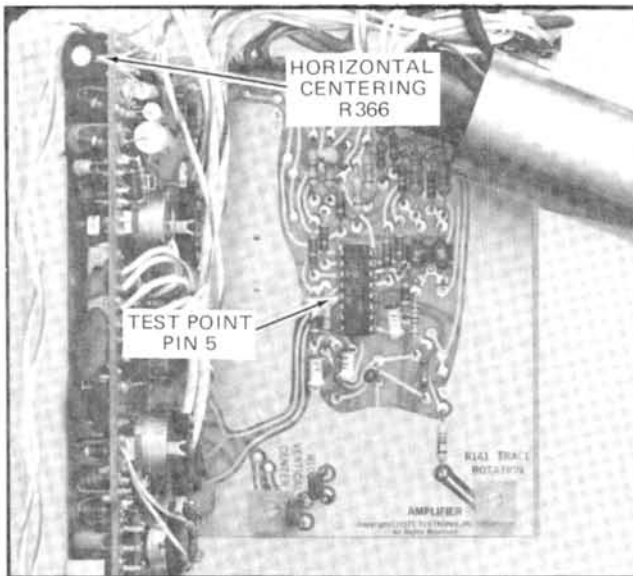

Fig. 4-9. Location of Horizontal Centering adjustment and test point.

25. Adjust Horizontal Gain

a. Connect the CH 1 probe tip to the output of the Standard Amplitude Calibrator via a probe tip-to-BNC adapter.

b. Adjust the Standard Amplitude Calibrator for a 20 mV output signal.

c. Set the CH 1 INPUT COUPLING switch to DC.

d. CHECK—The CRT display for two dots separated horizontally by four divisions, ± 0.2 division.

e. ADJUST—HORIZ GAIN, R475 (located on the side panel) for four divisions of deflection between the dots.

f. Disconnect the CH 1 probe from the Standard Amplitude Calibrator.

26. Adjust Sweep Calibration

a. Connect the CH 1 probe tip to the output of the Time-Mark Generator (Type 2901) via a probe tip-to-BNC adapter.

b. Set the SEC/DIV switch to 1 m and the Time-Mark Generator for 1 millisecond time markers.

c. Set the CH 2 POS control to the OFF detent.

d. Adjust the CH 1 VOLTS/DIV switch for a display about three divisions in amplitude.

e. CHECK—CRT display for 1 time marker/division. With the second time marker aligned with the first division vertical line, the tenth time marker should align with the ninth division vertical line, within ± 0.4 division.

Calibration—214 Service

f. ADJUST—SWP CAL, R370 (located on the side panel) for exactly eight divisions of deflection between the second and tenth time markers.

27. Check Variable Horizontal Magnifier Range

a. Rotate the VAR HORIZ MAG control fully clockwise.

b. CHECK—The CRT display for at least five divisions between adjacent time markers. Five-division spacing indicates a VAR HORIZ MAG control range of at least 5:1.

c. Return the VAR HORIZ MAG control to the CAL detent.

28. Check SEC/DIV Accuracy

a. CHECK—Apply the appropriate time markers and check each position of the SEC/DIV switch for proper timing over the center eight division portion of each sweep, within 0.4 division.

<http://www.ebaman.com>

TROUBLESHOOTING AIDS

Diagrams Information

Complete circuit diagrams are given on the foldout pages in the Diagrams section. The circuit number and electrical value of each component in this instrument are shown on the diagrams (see first page of the Diagrams section for definition of the reference designators used to identify components in this instrument). Important waveforms are also shown on the diagram. The portions of the circuit mounted on circuit boards are enclosed with blue lines.

Fig. 5-1 shows the location of the circuit boards within the instrument, along with their assembly (a) numbers. The assembly numbers are also used on the diagrams to aid in locating the boards. Component locators are shown in the Diagrams section, on the back of the page opposite the circuit diagram, to aid in cross-referencing between the diagrams and the circuit boards. Each electrical component on the boards is identified by its circuit number on the component locators.

Component Color Coding

The resistors used in the 214 are either composition resistors or precision resistors. The resistance values are color-coded on the components with EIA color-code (some precision resistors may have the value printed on the body). The color-code is read starting with the stripe nearest the end of the resistor. Composition resistors have four stripes which consist of two significant figures, a multiplier, and a tolerance value (see Fig. 5-2). Precision resistors have five stripes consisting of three significant figures, a multiplier, and a tolerance value.

The capacitance values of common disc capacitors and small tubular electrolytics are marked in microfarads on the side of the component body. The molded electrolytic capacitors are color-coded in picofarads (see Fig. 5-2).

The cathode end of each glass-encased diode is indicated by a stripe, a series of stripes, or a dot.

Troubleshooting Equipment

The majority of troubleshooting to be done on the 214 can be accomplished with a 20,000 ohms/volt VOM such as a Triplet Model 230-NA or a Simpson Model 262. Use a dynamic semiconductor tester, such as a Tektronix Type 577 Curve Tracer System, to check the semiconductors used in the 214. To check waveforms in this instrument, use a test oscilloscope with at least a DC to 500 kilohertz frequency response and one millivolt to 50 volts/division deflection factor.

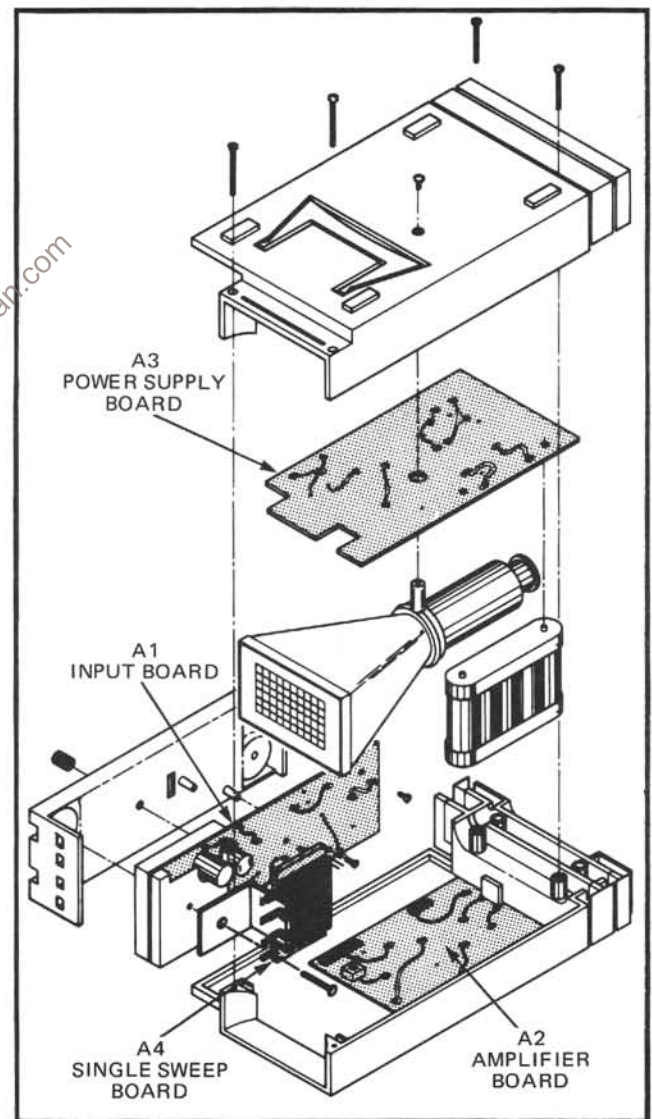

Fig. 5-1. Location of circuit boards within the 214.

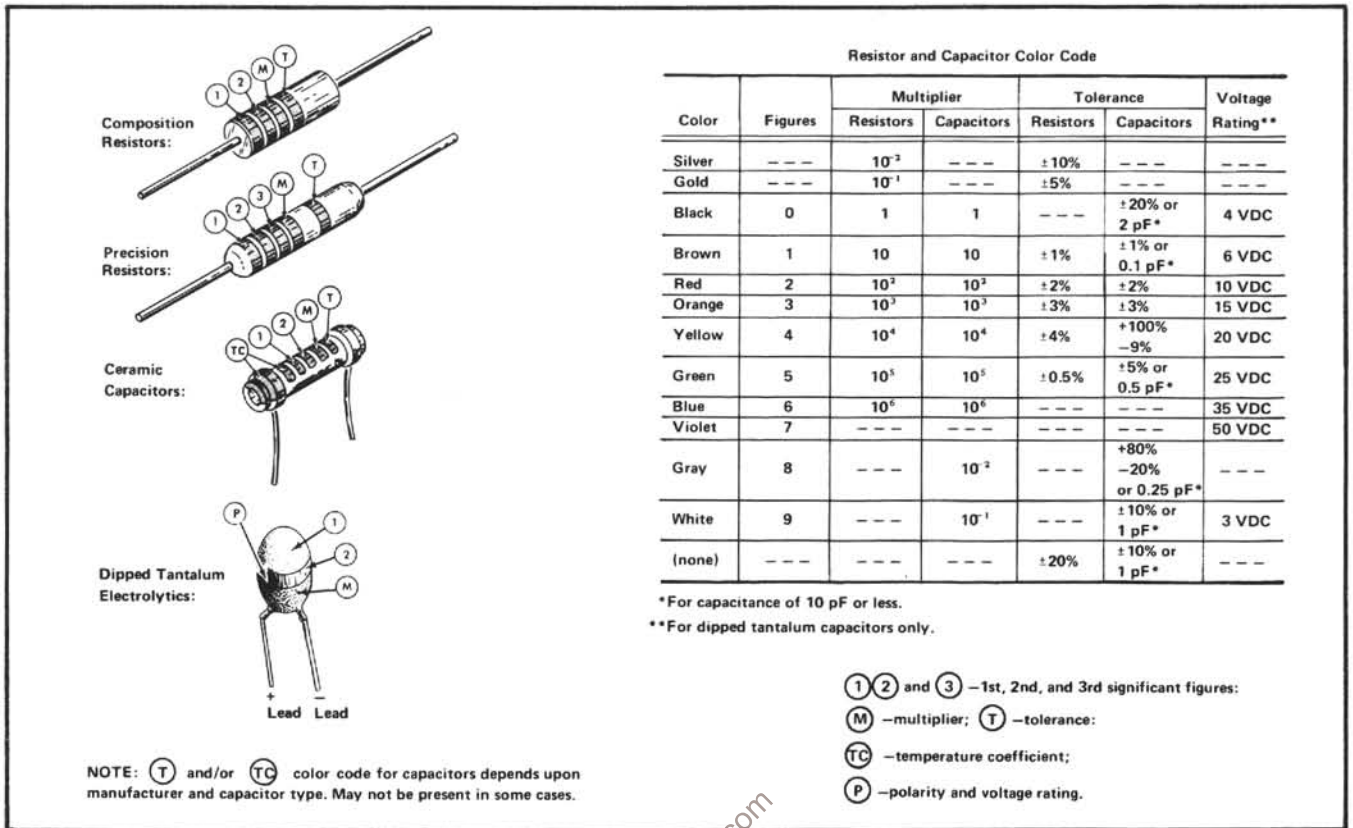

Fig. 5-2. Color code for resistors, ceramic capacitors, and dipped tantalum electrolytic capacitors.

CIRCUIT DESCRIPTION

The following circuit description begins with a discussion of the instrument using the block diagram located in the Diagram section at the rear of this manual. Then each circuit is described in detail, using detailed diagrams where necessary to show the interconnections between the stages in each major circuit and the relationship of the external controls to the individual stages. In addition to the block diagram, complete schematics are given in the Diagram section.

BLOCK DIAGRAM DESCRIPTION

Signals to be displayed on the CRT are applied to the tips of the signal probes. The signals are then amplified by the appropriate channel Input Amplifier circuit, consisting of a two-section source-follower stage and two feedback amplifiers. The Input Amplifier circuits also contain the vertical deflection, position (with channel on-OFF), input coupling, variable attenuation, and balance controls.

The Trigger Generator circuit initiates the sweep signal produced by the Sweep Generator. The input signal to the Trigger Generator can be selected internally either from the capacitively coupled CH 1 Input Amplifier signal, or from the directly coupled COMP signal of the Feedback Amplifier. The Trigger Generator input signal can also be selected from the external signal applied to the EXT TRIG banana jack. The Trigger Generator circuit contains coupling and source controls in addition to a combination level/slope control.

The Sweep Generator circuit produces a linear sawtooth output signal when initiated by the Trigger Generator circuit. The slope of the sawtooth produced by the Sweep Generator circuit is controlled by the SEC/DIV switch. The operating mode of the Sweep Generator circuit is determined by the Trigger LEVEL/SLOPE control and the SINGLE SWP pushbutton. In the AUTO PRESET detent, the absence of an adequate trigger signal causes the sweep to free run. When the LEVEL/SLOPE control is out of the AUTO PRESET detent, a horizontal sweep is presented only when correctly triggered by an adequate trigger signal.

The Single Sweep mode of operation allows one (and only one) triggered sweep to be initiated after the circuit is reset with the RESET button. The Sweep Generator also produces an unblanking gate signal coincident with the sawtooth waveform. This gate signal unblanks the CRT to permit display presentation.

The output of the Sweep Generator circuit is amplified by the Horizontal Amplifier circuit to produce the correct horizontal deflection for the CRT for all positions of the SEC/DIV switch. The Horizontal Amplifier contains a variable magnifier to increase the sweep rate up to at least a maximum of five times in any position of the SEC/DIV switch.

The CRT circuit contains the controls necessary for operation of the cathode-ray tube. Trace storage is accomplished by the Storage circuit. The Power Supply and CRT circuits provide all the voltages necessary for operation of this instrument.

CIRCUIT OPERATION

In the following description of the electrical operation and relationship of the circuits in the 214, circuitry commonly used by Tektronix is only briefly explained. If more information is desired on the commonly used circuits, refer to the following textbooks:

Phillip Cutler, "Semiconductor Circuit Analysis", McGraw-Hill, New York, 1964.

Lloyd P. Hunter (Ed.), "Handbook of Semiconductor Electronics", second edition, McGraw-Hill, New York, 1962.

Jacob Millman and Herbert Taub, "Pulse, Digital, and Switching Waveforms", McGraw-Hill, New York, 1965.

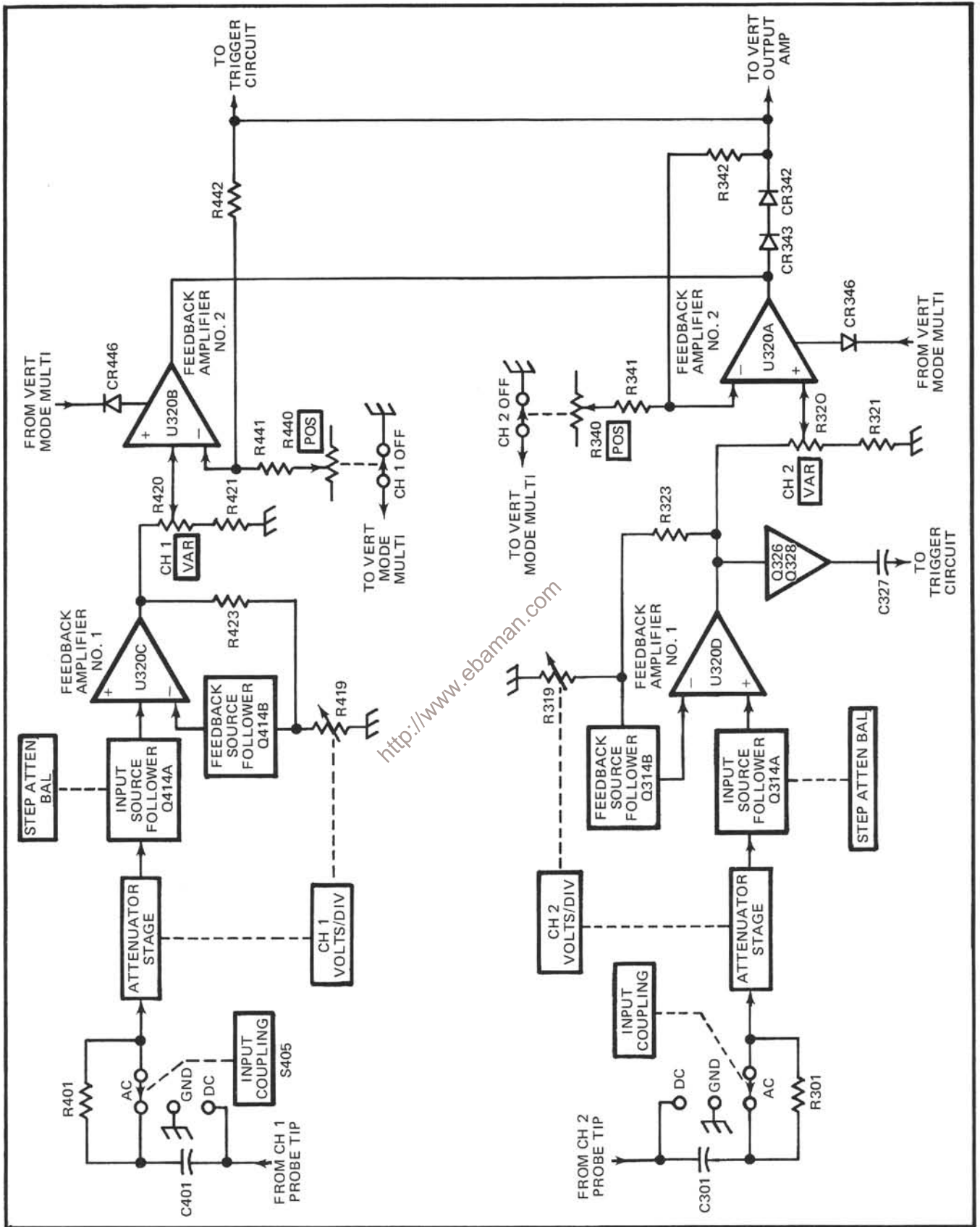

Fig. 6-1. Vertical input amplifiers detailed block diagram.

Vertical Input Amplifiers 1

Input signals for vertical deflection of the CRT of the 214 are applied to the tips of the attached probes. Each Input Amplifier provides control of input coupling, variable attenuation, vertical deflection factor, balance, and vertical position (with channel on-OFF) for the appropriate channel. Fig. 6-1 shows a detailed block diagram of the Vertical Input Amplifier circuit. A schematic of this circuit is shown on diagram 1.

Input signals applied to the tips of the probes are connected to the appropriate Attenuation Stage through the INPUT COUPLING switches (S305 and S405). The deflection factor in each channel is determined by the VOLTS/DIV switch (S310 or S410). In all positions of the VOLTS/DIV switches below .1 V/DIV, the correct deflection factor is achieved by changing the gain of Feedback Amplifiers U320-D and U320-C. In switch positions .1 V/DIV and up, precision attenuators are used (in addition to changing the gain of U320-D and U320-C) to achieve the correct deflection factors. When the VAR VOLTS/DIV control is rotated, the signal is attenuated across R320 and R420. This offers variable (uncalibrated) deflection factors between the calibrated settings of the VOLTS/DIV switch. The STEP ATTEN BAL adjustments (R315 and R417) control the trace shift when switching between deflection factors.

The 214 can be operated single trace by turning either vertical POS control to the OFF detent; this disables that channel in the last feedback stage of the Input Amplifier through the operation of the Vertical Mode Multivibrator U440. The CH 2 trigger signal is present regardless of the CH 2 POS control setting. In the dual-trace mode, the instrument will automatically chop or alternate, depending upon the sweep rate.

Vertical and Horizontal Output Amplifiers 2

The Vertical and Horizontal Output Amplifiers provide the final amplification for the deflection signals. Fig. 6-2 shows a detailed block diagram of these Output Amplifiers. A schematic of these circuits is on diagram 2.

Both amplifiers contain the same basic circuitry. The single-ended input signals are applied to paraphase amplifiers, U105-A and U105-B, to convert the signal into push-pull output signals. The Vertical Paraphase Amplifier stage contains the VERT GAIN adjustment (R470) that sets the overall gain of the vertical system, and a Vertical Centering adjustment (R101) to set DC centering. The Horizontal Paraphase Amplifier stage contains the HORIZ GAIN adjustment (R475), the VAR HORIZ MAG control (R476), and the Horizontal POS control (R480). The

output signals from the Paraphase Amplifiers receive final amplification in the common base Output Amplifier stages.

Trigger Generator 2

Integrated circuit U370 is a combination Trigger/Sweep Generator. The Trigger portion derives trigger signals internally, either from the capacitively coupled CH 2 Vertical Input Amplifier, or from the directly coupled COMP signal from the input of the Vertical Output Amplifier. The Trigger Generator can also select signals from an external signal applied to the EXT TRIG input banana jack. Controls are provided in this circuit to select trigger level, slope, and source. Fig. 6-3 shows a detailed block diagram of the Trigger/Sweep Generator circuits. A schematic of this circuit is on diagram 2.

Sweep Generator 2

The Sweep Generator portion of U370 serves a multiple purpose. In all positions of the SEC/DIV switch, except X-Y, the Sweep Generator is an integrator, which generates a linear sawtooth voltage waveform. This output signal is produced on command (trigger pulse) from the Trigger Generator circuit. The slope of the sawtooth voltage is controlled by the setting of the SEC/DIV (S360) switch.

The Sweep Generator also produces an unblanking gate signal coincident with the sawtooth waveform. This gate signal is amplified by Unblanking Amplifier Q134 and applied to the CRT to unblank the CRT during sweep presentation. In addition, the Sweep Generator supplies the clock pulses to the Vertical Mode Multivibrator (U440) for alternate switching between channels. In the X-Y position of the SEC/DIV switch, the Sweep Generator becomes a feedback amplifier to amplify the signal applied to the CH 1 probe tip. Fig. 6-3 shows a detailed block diagram of the Trigger/Sweep Generator circuits. A schematic of this circuit is on diagram 2.

Single Sweep 3

In the Single Sweep mode of operation, the Auto Trigger is disabled and sweep initiation is controlled by the Single Sweep Reset circuit. Also, Sweep Start Holdoff is controlled by latch circuit Q532 and Q535 instead of the Sweep Generator. A schematic of the Single Sweep circuit is on diagram 3.

The Sweep Start Holdoff waveform (see Fig. 6-4) from the Sweep Generator is applied to the Single Sweep circuit. The positive-going step of this waveform (Sweep Start) is coupled through C530 to turn on Q530. When Q530 turns

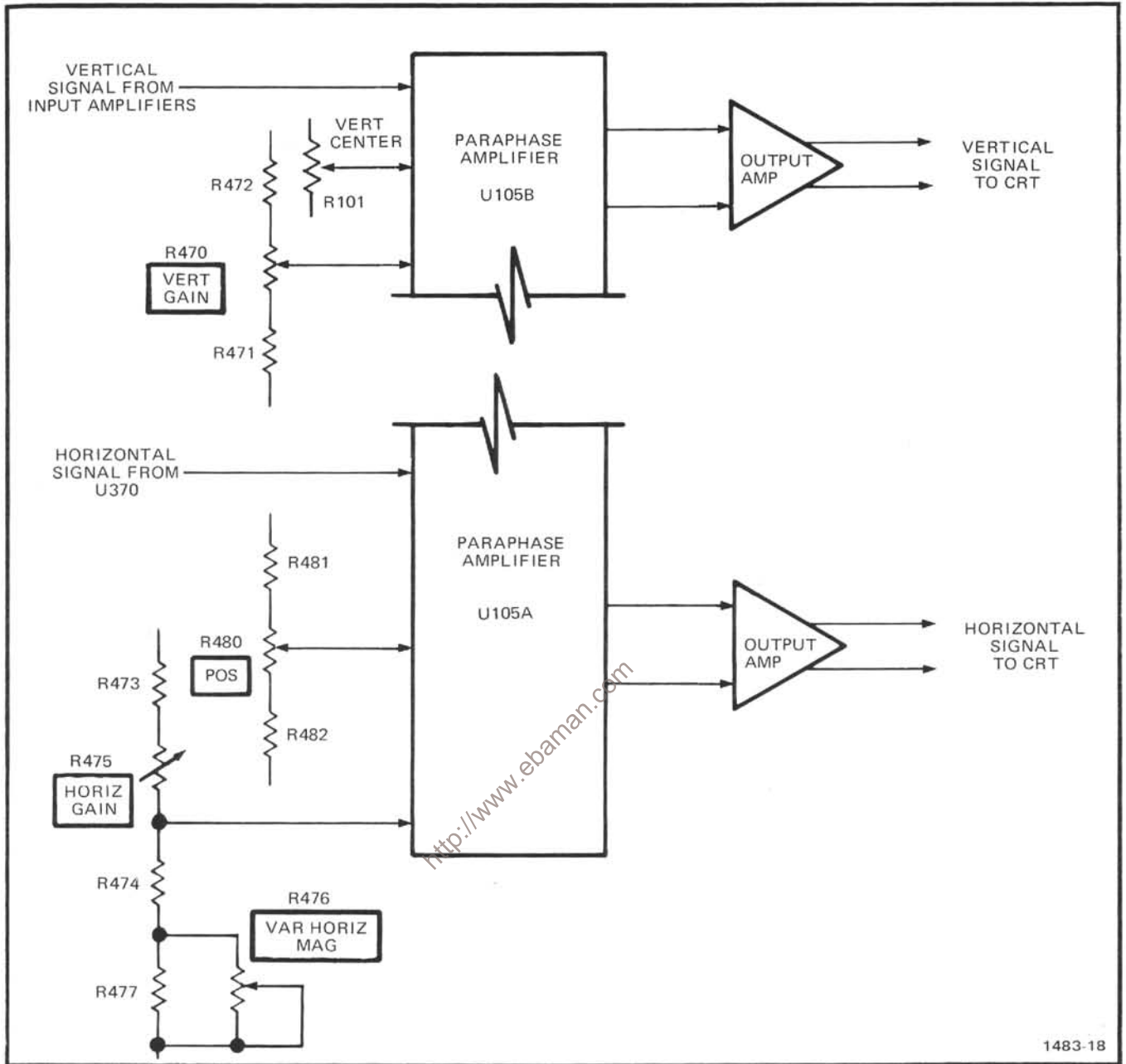

Fig. 6-2. Vertical and Horizontal output amplifiers detailed block diagram.

on, the latch circuit (Q532 and Q535) is disabled. The emitter of Q532 is held positive, preventing the Sweep Start Holdoff from returning to the Sweep Ready state.

When the RESET button is pressed, the latch circuit is again enabled and Q530 is turned off. At this time the READY indicator light, DS535, turns on. The next Trigger Pulse received by the Sweep Generator ends the Sweep Start Holdoff and initiates a sweep.

Storage 3

The Storage circuit provides the voltage levels necessary to operate the flood gun, wall band, and target. Additional circuitry included is the Enhance Amplifier, which permits fast Single Sweep displays to be Stored. Fig. 6-5 shows a detailed block diagram of the Storage circuit; a schematic is on diagram 3.

The CRT used in the 214 is a direct-view bistable storage cathode-ray tube containing special storage elements in

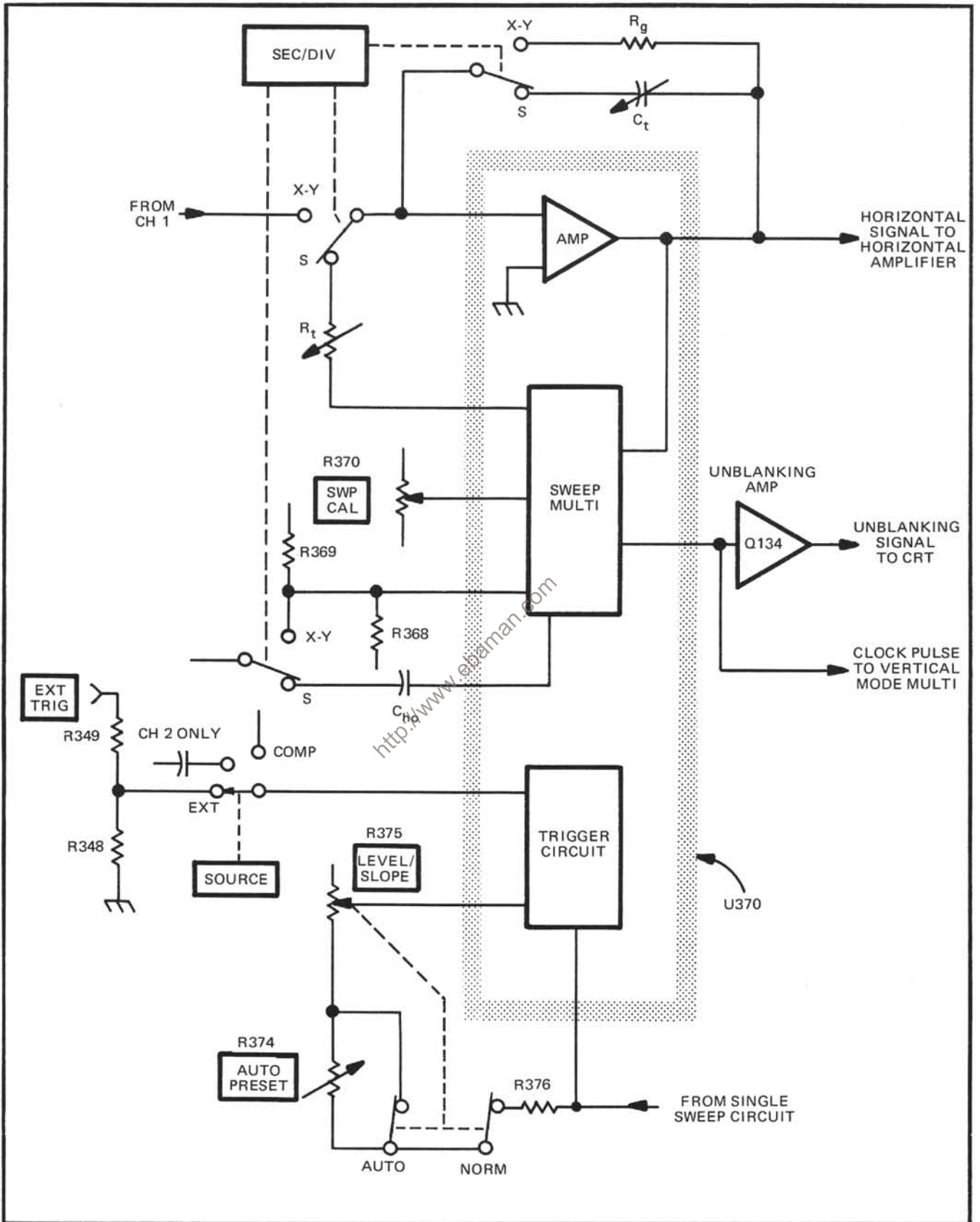

Fig. 6-3. Trigger/Sweep Generator detailed block diagram.

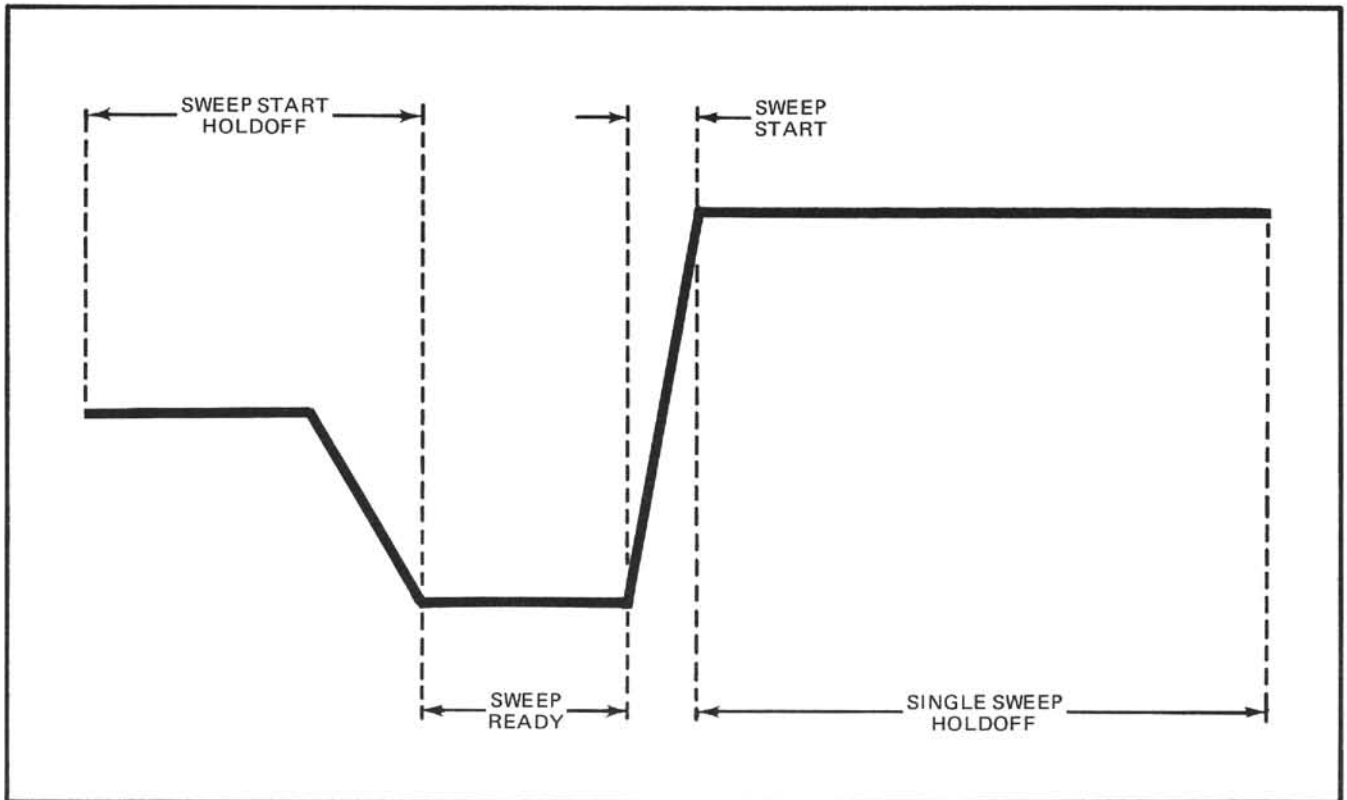

Fig. 6-4. Identification of portions of the Sweep Start Holdoff waveform at Pin 5 of the Single Sweep Board.

In addition to the conventional writing gun elements, the operating mode of the tube depends primarily on the voltages applied to these storage electrodes. With one condition of applied potentials, the Storage screen (target) operates in the ready-to-write state; then, when it is bombarded with high energy writing beam current, the bombarded portion shifts to the STORED mode to store a written display. With a different set of applied voltages, the target operates in the conventional, NONSTORE, mode.

Power is applied by the -100 volt supply to the flood gun, and the Storage circuit only with the STORE button pushed in. This reduces the power drain from the batteries when in the NONSTORE mode of operation. Differences in the CRT sensitivity between STORE and NONSTORE modes are compensated for by the Store Gain control, R275.

The wall band serves as a lens to distribute the flood gun electrons uniformly over the storage target, and has no effect on the bombarding energy of the electrons. The voltage level of the wall band is determined by R506 through Q505. The ready-to-write potential of the target is set by Operational Level control R510 in the Target Control Amplifier (Q510, Q512).

Storage Erase. Erase of a Stored display is achieved by pressing and releasing the ERASE button. As the switch makes contact, a positive-going pulse (about $+155$ V) is applied to the target and wall band through the Target Control & Wall Board Amplifiers. This pulse raises the target voltage above the writing threshold and writes the entire target with flood gun electrons.

When the ERASE button is released, a negative-going pulse (about -155 V) is applied to the target and wall band, pulling the target voltage below the ready-to-write potential. Then the target and wall band are gradually returned to the ready-to-write state.

Enhance Amplifier. Automated Enhance occurs only in the Store, Single Sweep Mode of operation and at sweep rates of 0.1 millisecond/division and above. The Enhance Amplifier (Q520 and Q521) receives a negative pulse from the Single Sweep Reset circuit when the READY light is extinguished. With power applied to the Enhance Amplifier from the SEC/DIV switch, the Enhance Amplifier produces a positive pulse to the Target Control Amplifier and wall band circuits. The amplitude of this Enhance pulse is determined by the Enhance Level control, R526. This

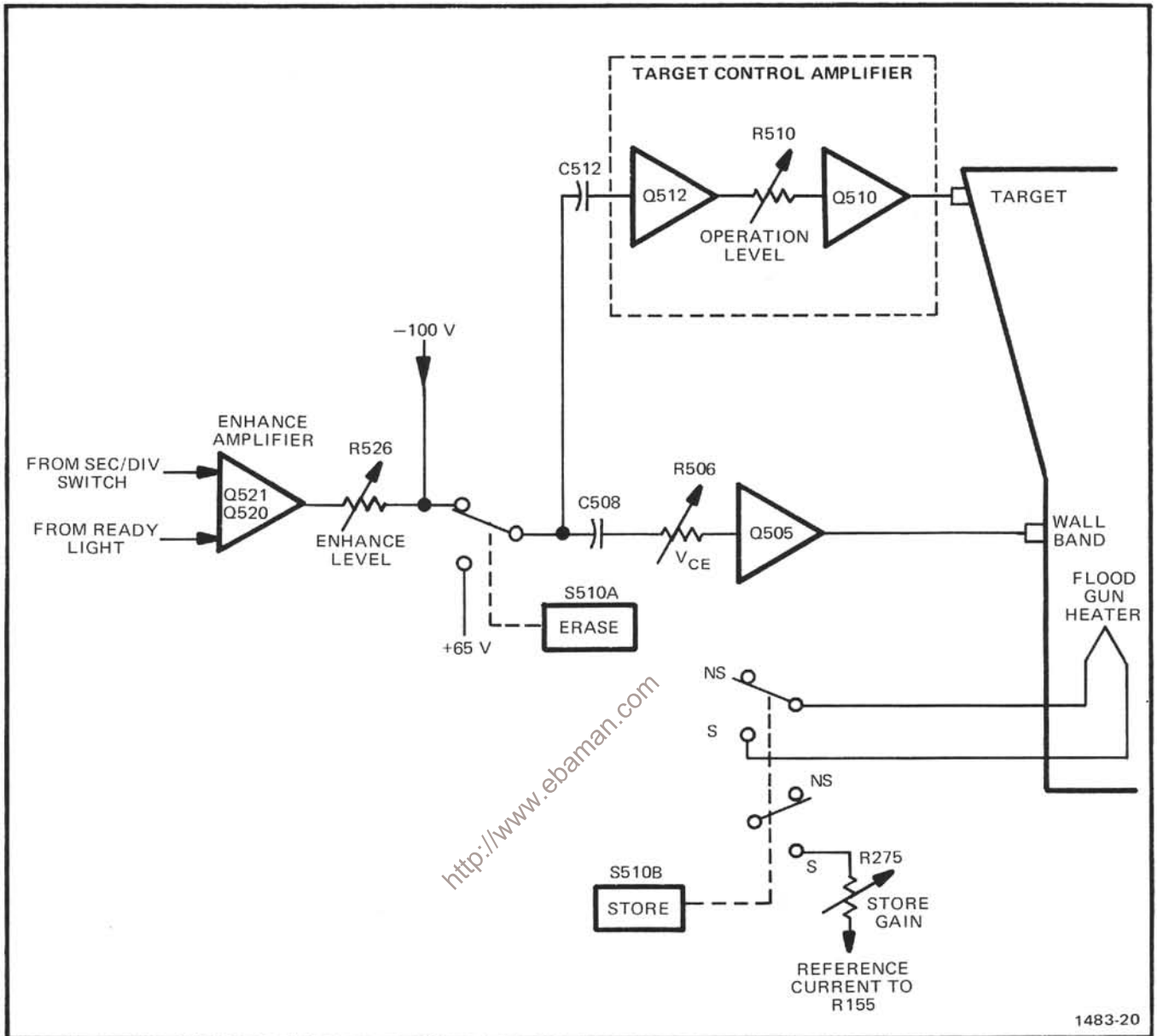

Fig. 6-5. Storage circuit detailed block diagram.

Enhance pulse conditions the target so that less writing gun current is required to shift the written section to the STORED state.

Power Supply 4

The Power Supply provides the power necessary to operate this instrument or, if the instrument is turned off and connected to an AC line, to recharge the batteries. Fig. 6-6 shows a detailed block of this circuit. A schematic of this circuit is on diagram 4.

When the instrument is connected to a power line the AC power is capacitively coupled to the Power Rectifier. The rectified DC is used to either run the instrument or to recharge the internal batteries. The batteries act as a large filter capacitor for the Input Rectifier in the AC line mode of operation. When the instrument is not connected to a power line, operating power is provided by the batteries. The POWER (BATTERY) indicator, light emitting diode DS310, is illuminated when the 214 is operating from line voltage or adequately charged batteries. When about five minutes of operating time remains, the battery charge drops to a point where DS310 will extinguish. When the charge level of the batteries falls below about +10 volts, the

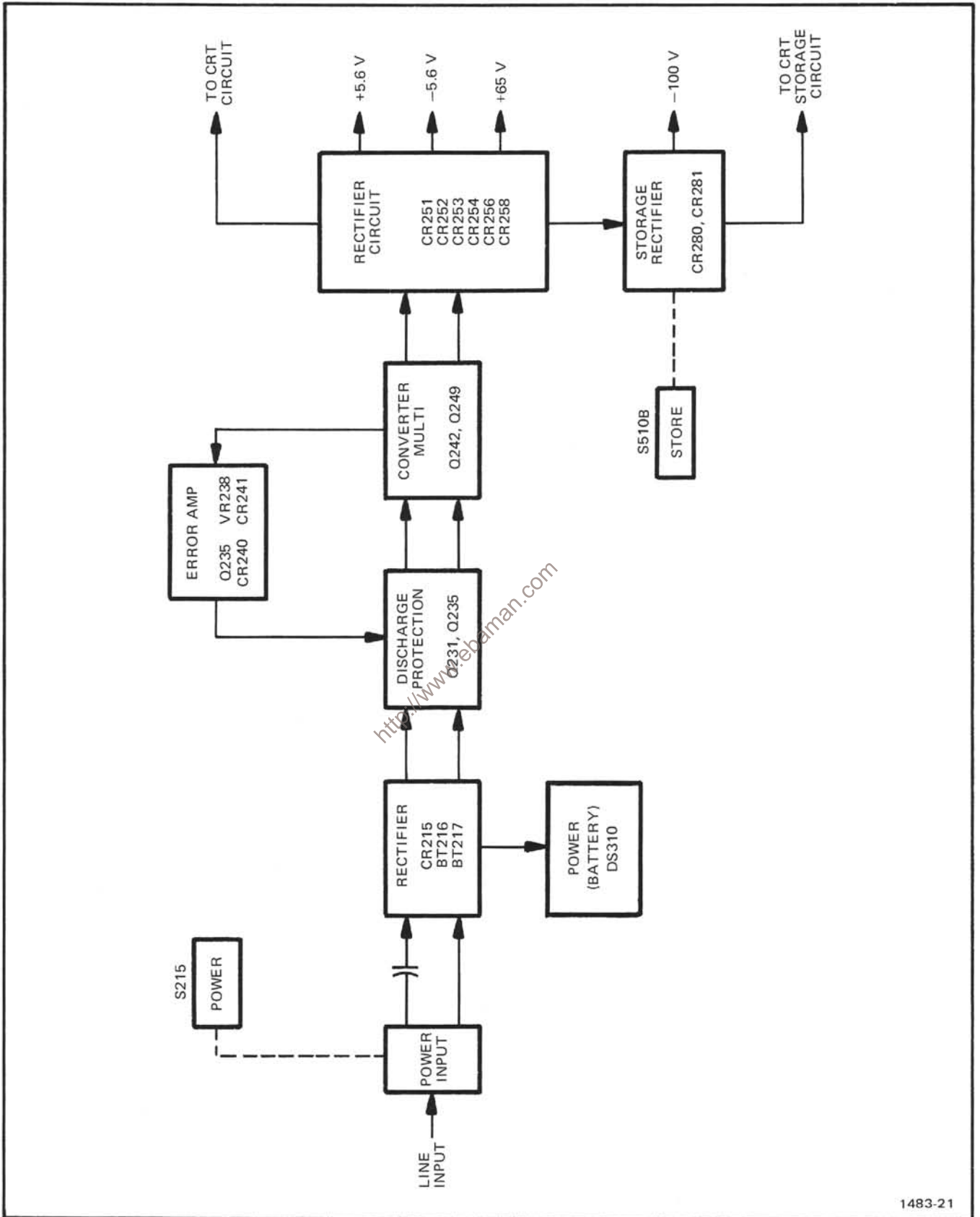

Fig. 6-6. Power Supply circuit detailed block diagram.

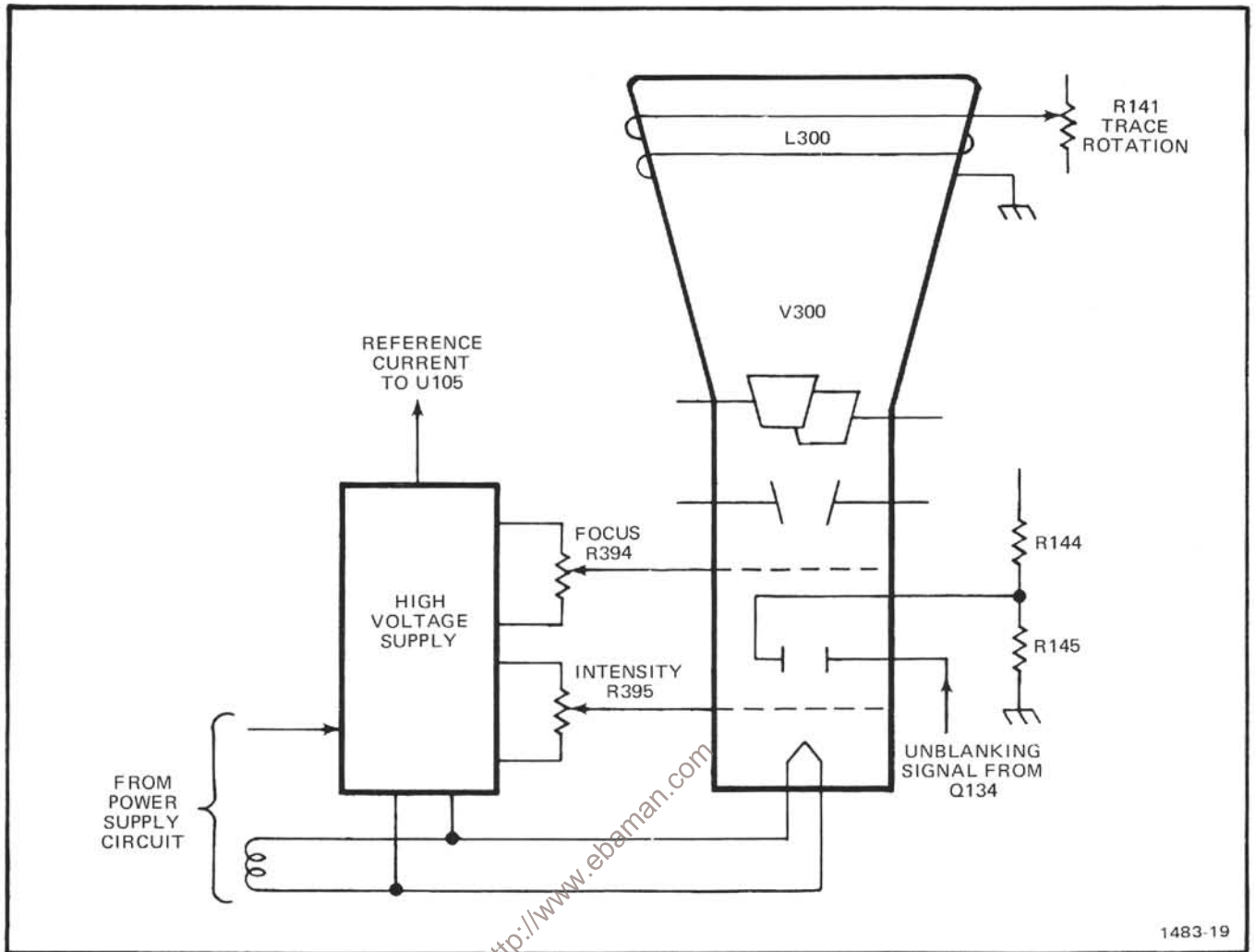

Fig. 6-7. CRT Circuit detailed block diagram.

Discharge Protection circuit (Q231 and Q235) prevents the Converter Multivibrator (Q242 and Q249) from functioning. The Converter Multivibrator changes DC into AC, which is applied across T250 and then rectified into the appropriate DC voltages in the Rectifier circuit. Q242 and Q249, together with VR238, also act as a Regulator in the Primary of T250. Error Amp Q235, VR238, CR240, and CR241 controls the voltage changes to the Converter Multivibrator.

Power is applied to T280 to activate the -100 volt supplies, and the flood gun of the CRT only in the STORE mode of operation. This reduces the power drain from the batteries when operating in the NONSTORE mode.

CRT Circuit 3

The CRT circuit provides the high voltage and control circuits necessary for operation of the cathode-ray tube

(CRT). Fig. 6-7 shows a detailed block diagram of the CRT circuit. A schematic of this circuit is on diagram 3.

NOTE

See the Storage Circuit description for operation of the CRT in the STORE mode.

Rectifiers CR261 through CR268 provide the negative accelerating potential for the CRT. Voltage output is approximately -1000 volts at the CRT cathode. Filament voltage for the CRT is provided by a separate winding of T250. Display intensity and focus are controlled by R395 and R294 respectively. The Trace Rotation adjustment controls the current through L300 and affects both the vertical and horizontal alignment of the CRT beam.

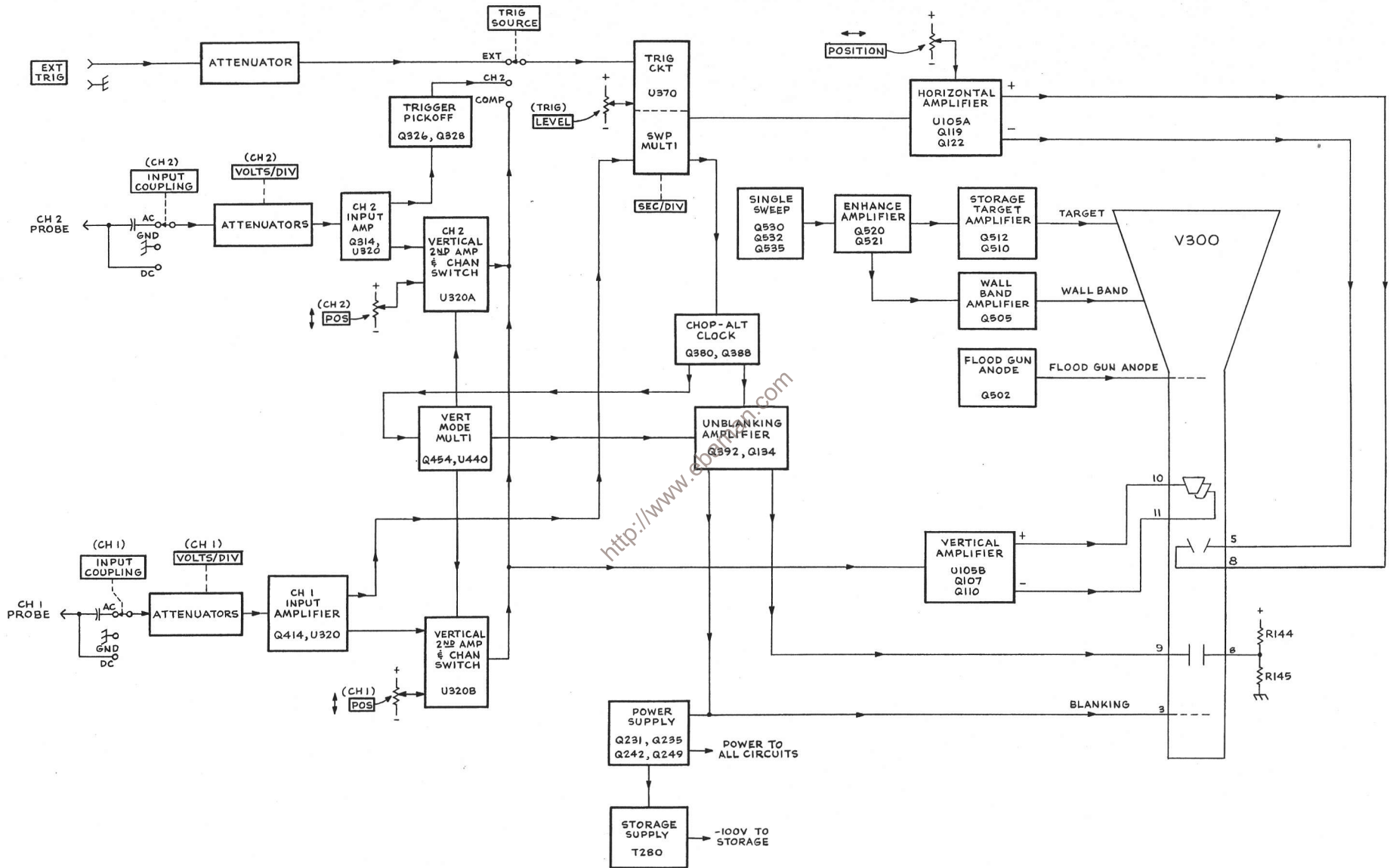

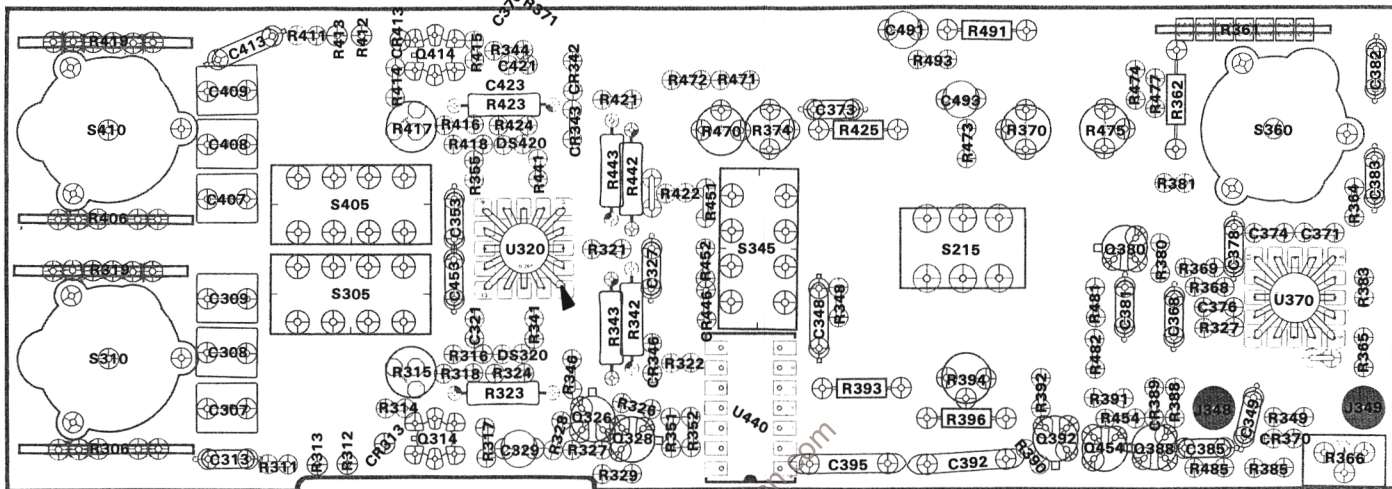

Top View

1483-40

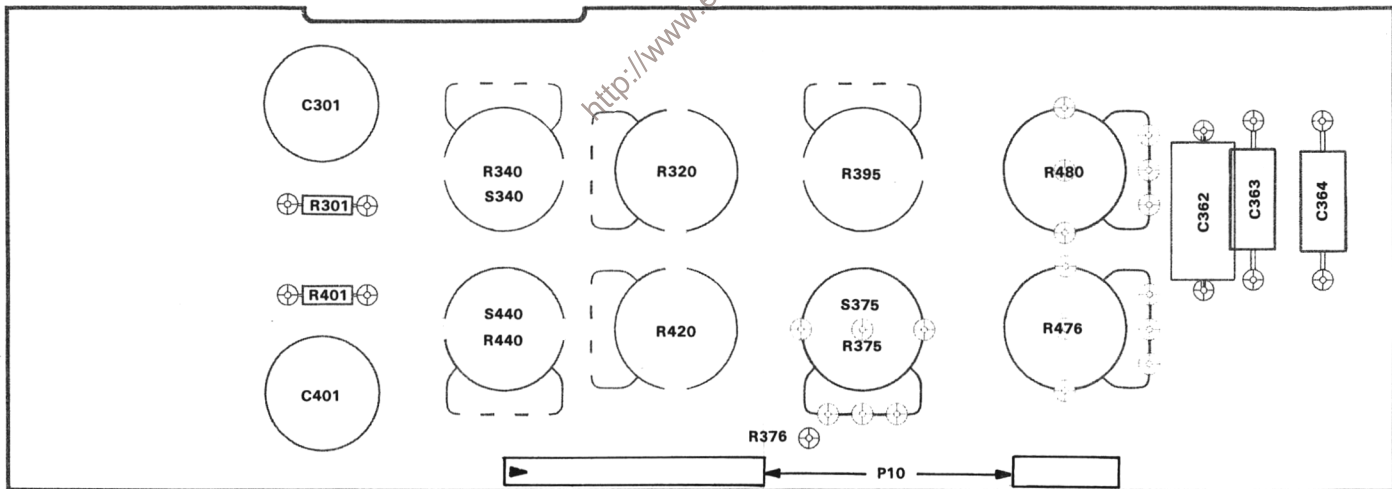

Bottom View

1483-41

VOLTAGES AND WAVEFORMS

The voltages and waveforms shown on this diagram were obtained by using the following test set-ups and test equipment.

Voltage Measurements:

Set the front and side panel controls to mid-range.

Input coupling switches to ground (GND). Trace positioned to the center horizontal line.

Voltmeter common is connected to the instrument common.

Waveform Measurements:

The 214 Oscilloscope under test: The front and side panel controls are set to mid-range. The input coupling switches are set to AC. The vertical deflection is set to 1 m with a two millivolt square wave connected to CH 1 and a two millivolt sine wave connected to CH 2. The SEC/DIV switch is set for 0.5 m with a triggered display.

Test Oscilloscope: The test oscilloscope is internally triggered; the vertical deflection and horizontal timing is indicated on the waveform photo. The vertical input is AC coupled. The tolerance of the voltages and waveforms is 20%. The test oscilloscope used for the wave forms was a Tektronix 7503 with a readout display.

RECOMMENDED TEST EQUIPMENT

ITEM	SPECIFICATIONS	RECOMMENDED TYPE
Oscilloscope	Frequency response 500 kilohertz.	Tektronix 211 or equivalent.
Voltmeter nonloading digital multimeter	Input impedance: 10 M Ω Range: 0–1 kV	Tektronix 7D13 Digital multimeter, test oscilloscope with readout is required. Fairchild Model 7050 or equivalent.

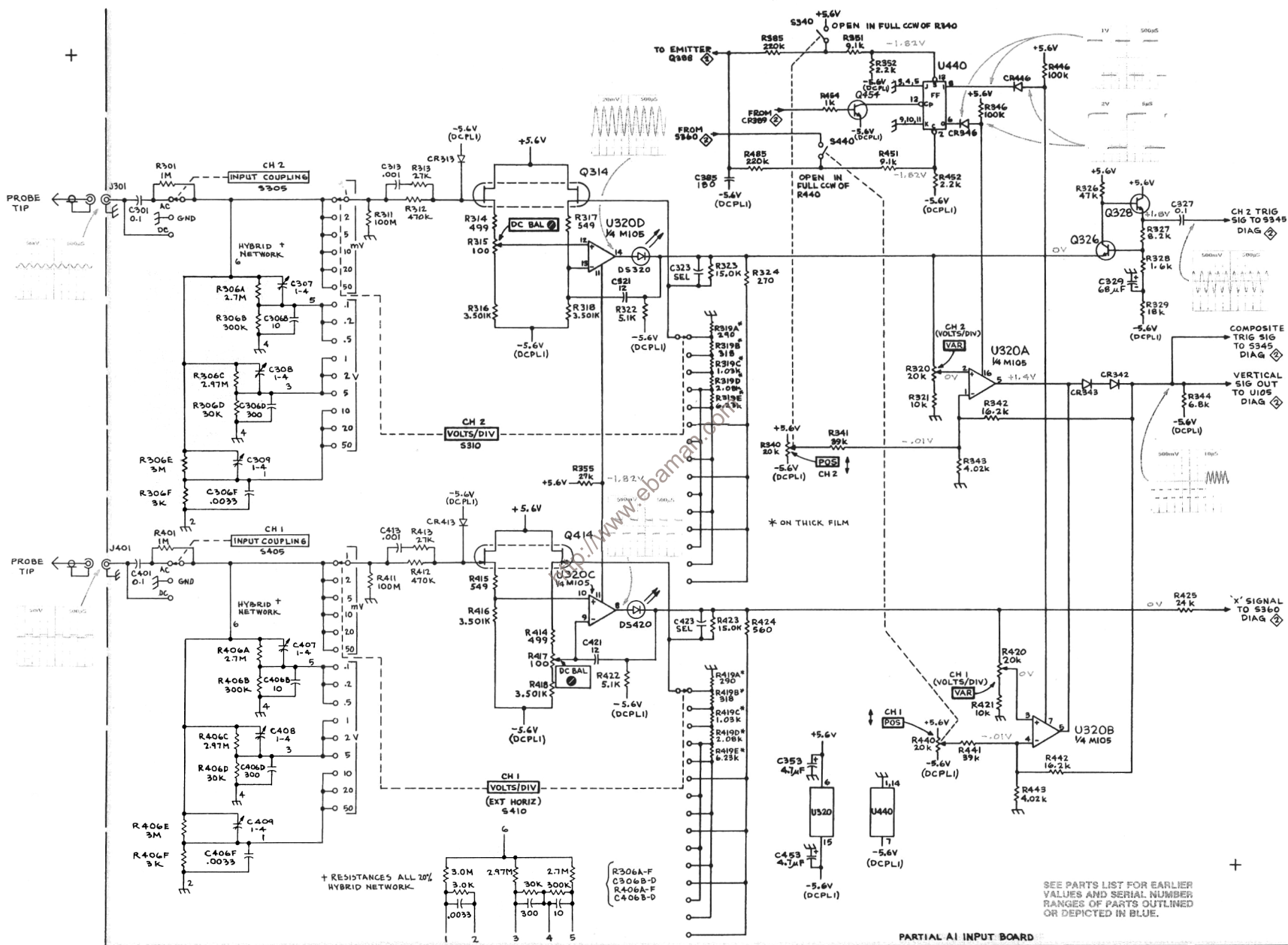

PARTIAL A1 INPUT BOARD

214 Service



J10

PIN ARRANGEMENT
EFFECTIVE BELOW
SN B054131

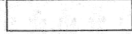
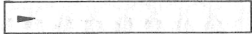
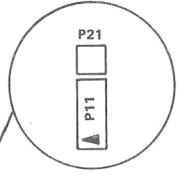

R132

C115

C113

R155

R125

C125

BT216

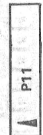

R101

C101

VERTICAL CENTER

C103

Copyright ©1974, TTK-SONIX, Inc.
All Rights Reserved

AMPLIFIER

R141

R141 TRACE
ROTATION

C153

R153

R117

R154

C104

C129

C150

R151

R105

R150

U105

R106

R109

L108

L111

R118

R113

R127

R134

R135

R108

R107

R111

R110

R122

R119

R137

R136

R108

R107

R111

R110

Q122

Q119

Q134

Q134

Q107

Q110



BT217

The voltages and waveforms shown on this diagram were obtained by using the following test set-ups and test equipment.

Waveform Measurements:

The 214 Oscilloscope under test: The front and side panel controls are set to mid-range. The input coupling switches are set to AC. The vertical deflection is set to 1 m with a two millivolt square wave connected to CH 1 and a two millivolt sine wave connected to CH 2. The SEC/DIV switch is set for 0.5 m with a triggered display.

Voltage Measurements:

Set the front and side panel controls to mid-range.

Input coupling switches to ground (GND). Trace positioned to the center horizontal line.

Test Oscilloscope: The test oscilloscope is internally triggered; the vertical deflection and horizontal timing is indicated on the waveform photo. The vertical input is AC coupled. The tolerance of the voltages and waveforms is 20%. The test oscilloscope used for the wave forms was a Tektronix 7503 with a readout display.

Voltmeter common is connected to the instrument common.

RECOMMENDED TEST EQUIPMENT

ITEM	SPECIFICATIONS	RECOMMENDED TYPE
Oscilloscope	Frequency response 500 kilohertz.	Tektronix 211 or equivalent.
Voltmeter nonloading digital multimeter	Input impedance: 10 MΩ Range: 0–1 kV	Tektronix 7D13 Digital multimeter, test oscilloscope with readout is required. Fairchild Model 7050 or equivalent.

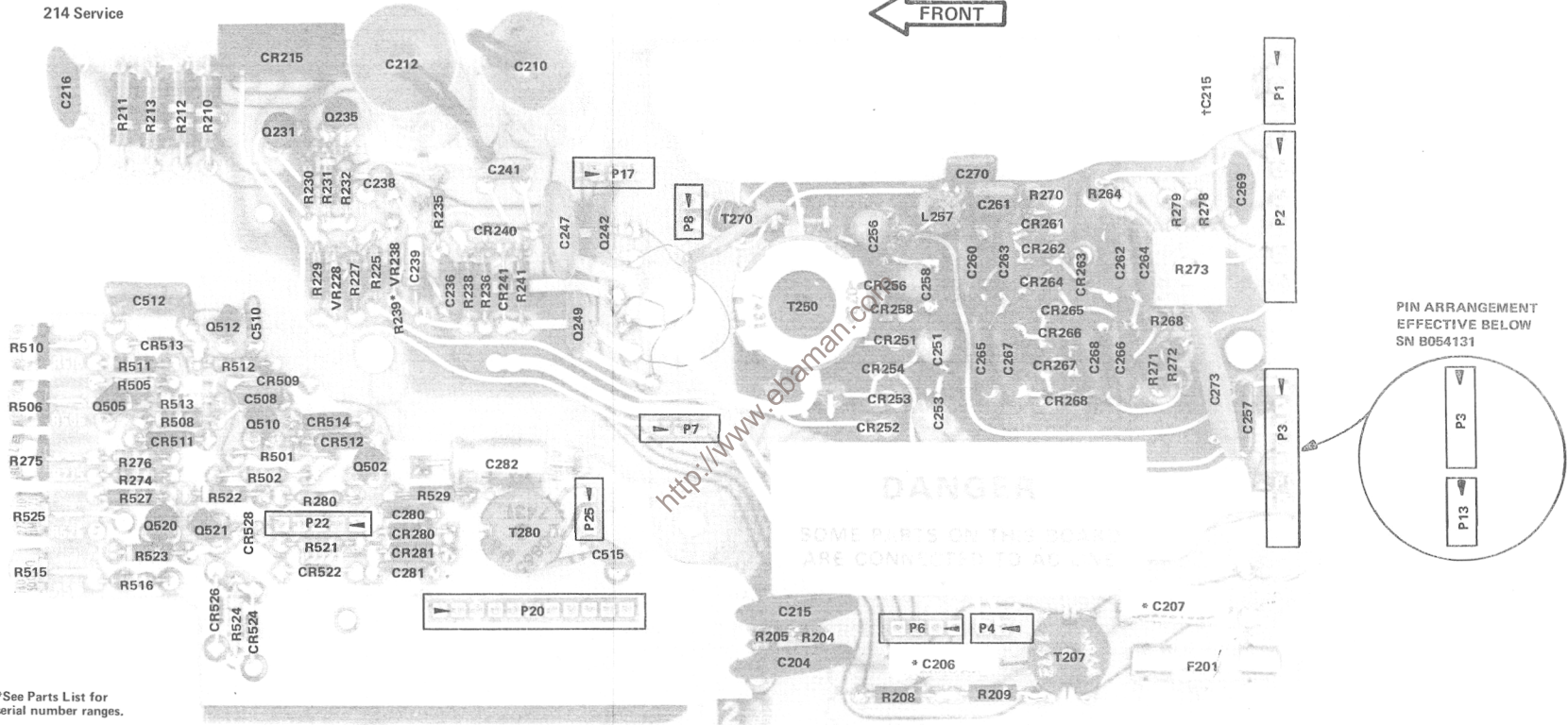

PIN ARRANGEMENT
EFFECTIVE BELOW
SN B054131

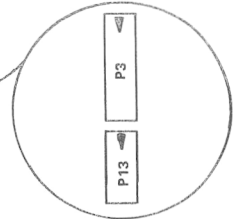

*See Parts List for serial number ranges.

†Early production location.

Fig. 9-3. A3 Power Supply Circuit Board.

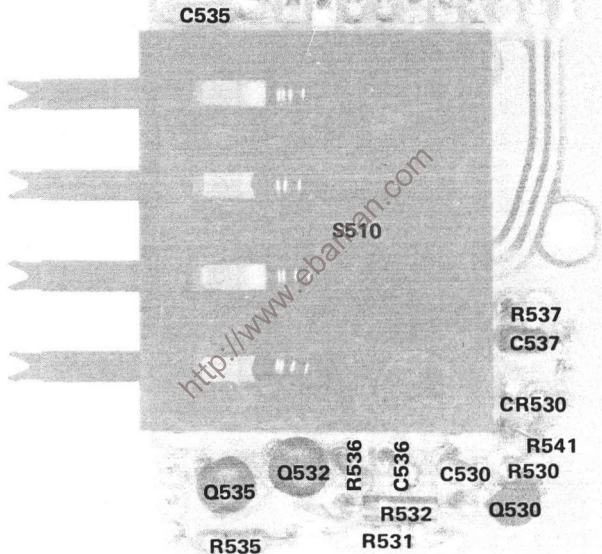
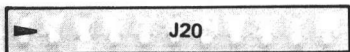

Fig. 9-4. A4 Single Sweep Board. 1483-38

VOLTAGES AND WAVEFORMS

The voltages and waveforms shown on this diagram were obtained by using the following test set-ups and test equipment.

Voltage Measurements:

Set the front and side panel controls to mid-range.

Input coupling switches to ground (GND). Trace positioned to the center horizontal line.

Voltmeter common is connected to the instrument common.

Waveform Measurements:

The 214 Oscilloscope under test: The front and side panel controls are set to mid-range. The input coupling switches are set to AC. The vertical deflection is set to 1 m with a two millivolt square wave connected to CH 1 and a two millivolt sine wave connected to CH 2. The SEC/DIV switch is set for 0.5 m with a triggered display.

Test Oscilloscope: The test oscilloscope is internally triggered; the vertical deflection and horizontal timing is indicated on the waveform photo. The vertical input is AC coupled. The tolerance of the voltages and waveforms is 20%. The test oscilloscope used for the wave forms was a Tektronix 7503 with a readout display.

RECOMMENDED TEST EQUIPMENT

ITEM	SPECIFICATIONS	RECOMMENDED TYPE
Oscilloscope	Frequency response 500 kilohertz.	Tektronix 211 or equivalent.
Voltmeter nonloading digital multimeter	Input impedance 10 MΩ Range: 0-100V	Tektronix 7D13 Digital multimeter, test oscilloscope with readout is required. Fairchild Model 7050 or equivalent.

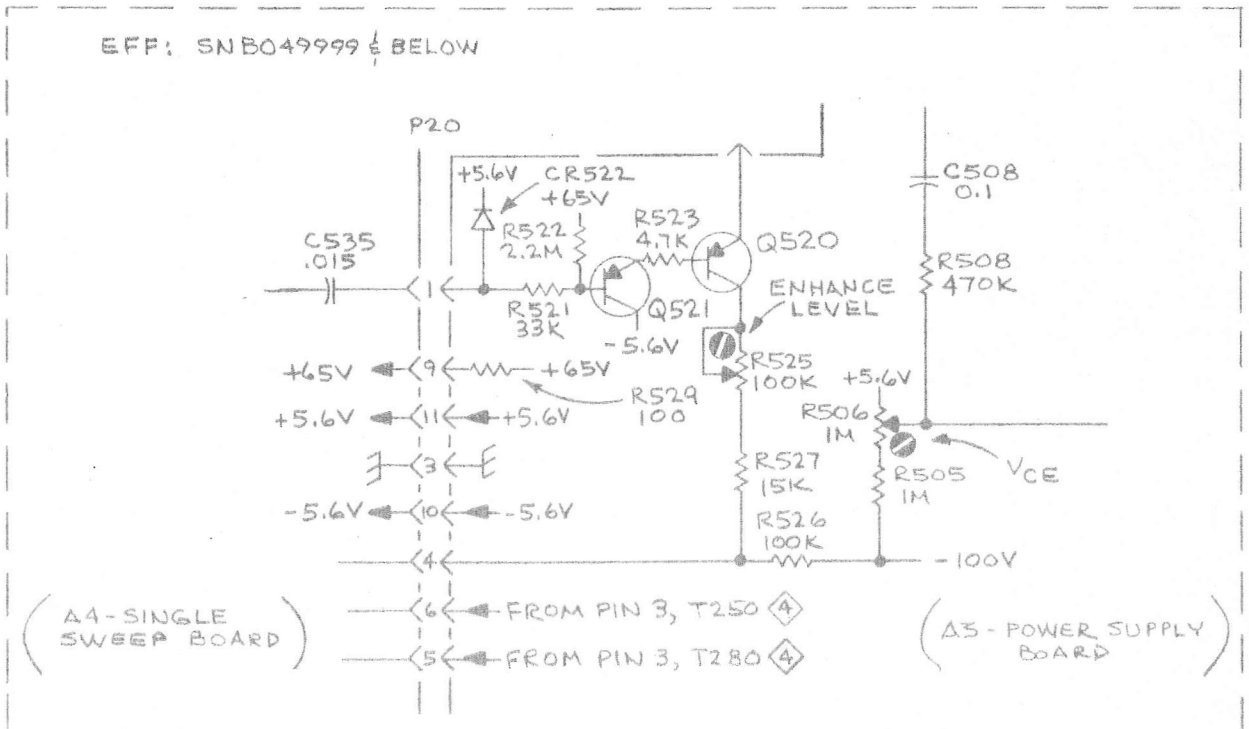

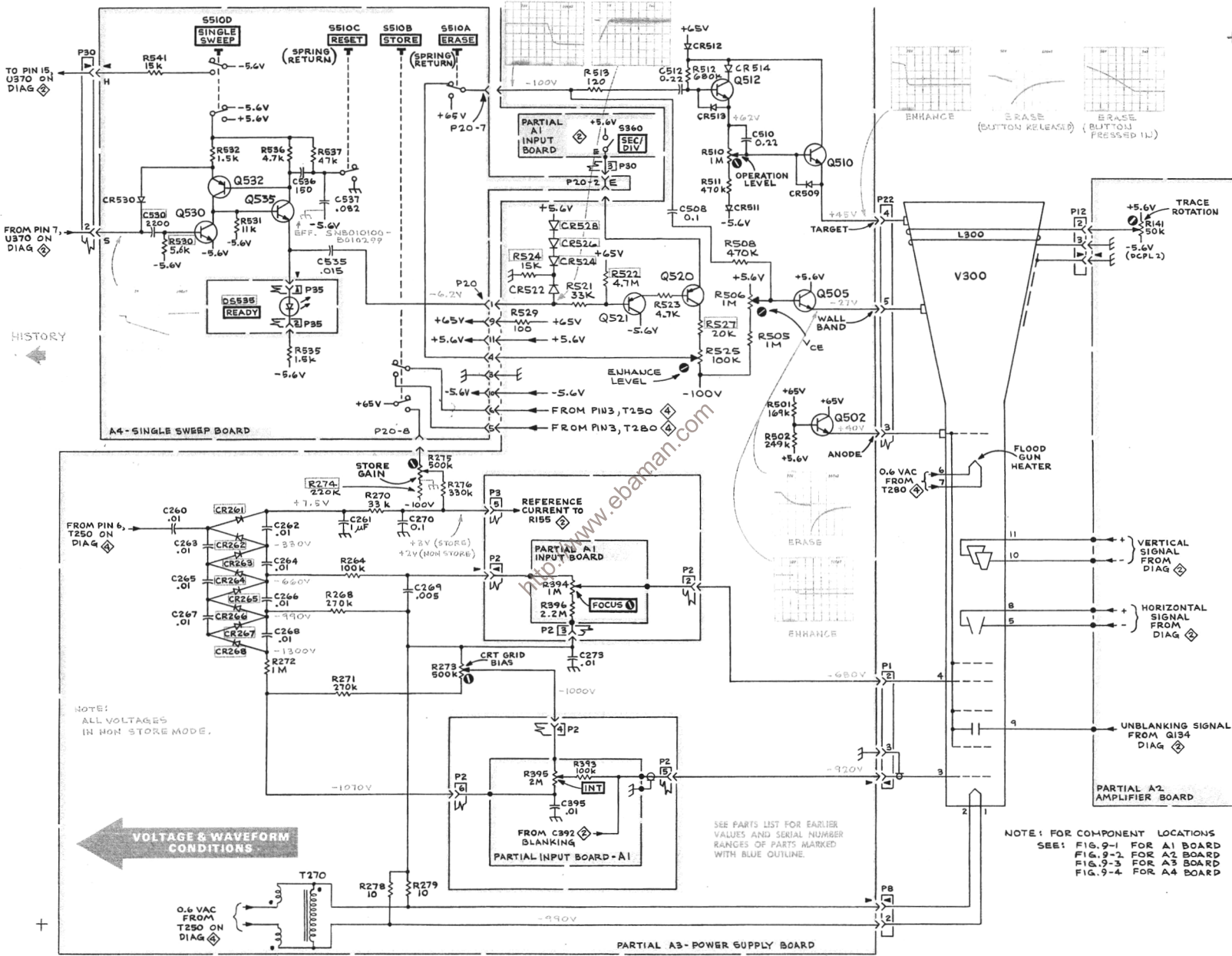

HISTORY ←

← VOLTAGE & WAVEFORM CONDITIONS

NOTE!
ALL VOLTAGES
IN HIGH STORE MODE.

NOTE: FOR COMPONENT LOCATIONS
SEE: FIG. 9-1 FOR A1 BOARD
FIG. 9-2 FOR A2 BOARD
FIG. 9-3 FOR A3 BOARD
FIG. 9-4 FOR A4 BOARD

SEE PARTS LIST FOR EARLIER
VALUES AND SERIAL NUMBER
RANGES OF PARTS MARKED
WITH BLUE OUTLINE.

VOLTAGES AND WAVEFORMS

The voltages and waveforms shown on this diagram were obtained by using the following test set-ups and test equipment.

Voltage Measurements:

Set the front and side panel controls to mid-range.

Input coupling switches to ground (GND). Trace positioned to the center horizontal line.

Voltmeter common is connected to the instrument common.

Waveform Measurements:

The 214 Oscilloscope under test: The front and side panel controls are set to mid-range. The input coupling switches are set to AC. The vertical deflection is set to 1 m with a two millivolt square wave connected to CH 1 and a two millivolt sine wave connected to CH 2. The SEC/DIV switch is set for 0.5 m with a triggered display.

Test Oscilloscope: The test oscilloscope is internally triggered; the vertical deflection and horizontal timing is indicated on the waveform photo. The vertical input is AC coupled. The tolerance of the voltages and waveforms is 20%. The test oscilloscope used for the wave forms was a Tektronix 7503 with a readout display.

RECOMMENDED TEST EQUIPMENT

ITEM	SPECIFICATIONS	RECOMMENDED TYPE
Oscilloscope	Frequency response 500 kilohertz.	Tektronix 211 or equivalent.
Voltmeter nonloading digital multimeter	Input impedance: 10 M Ω Range: 0–1 kV	Tektronix 7D13 Digital multimeter, test oscilloscope with readout is required. Fairchild Model 7050 or equivalent.

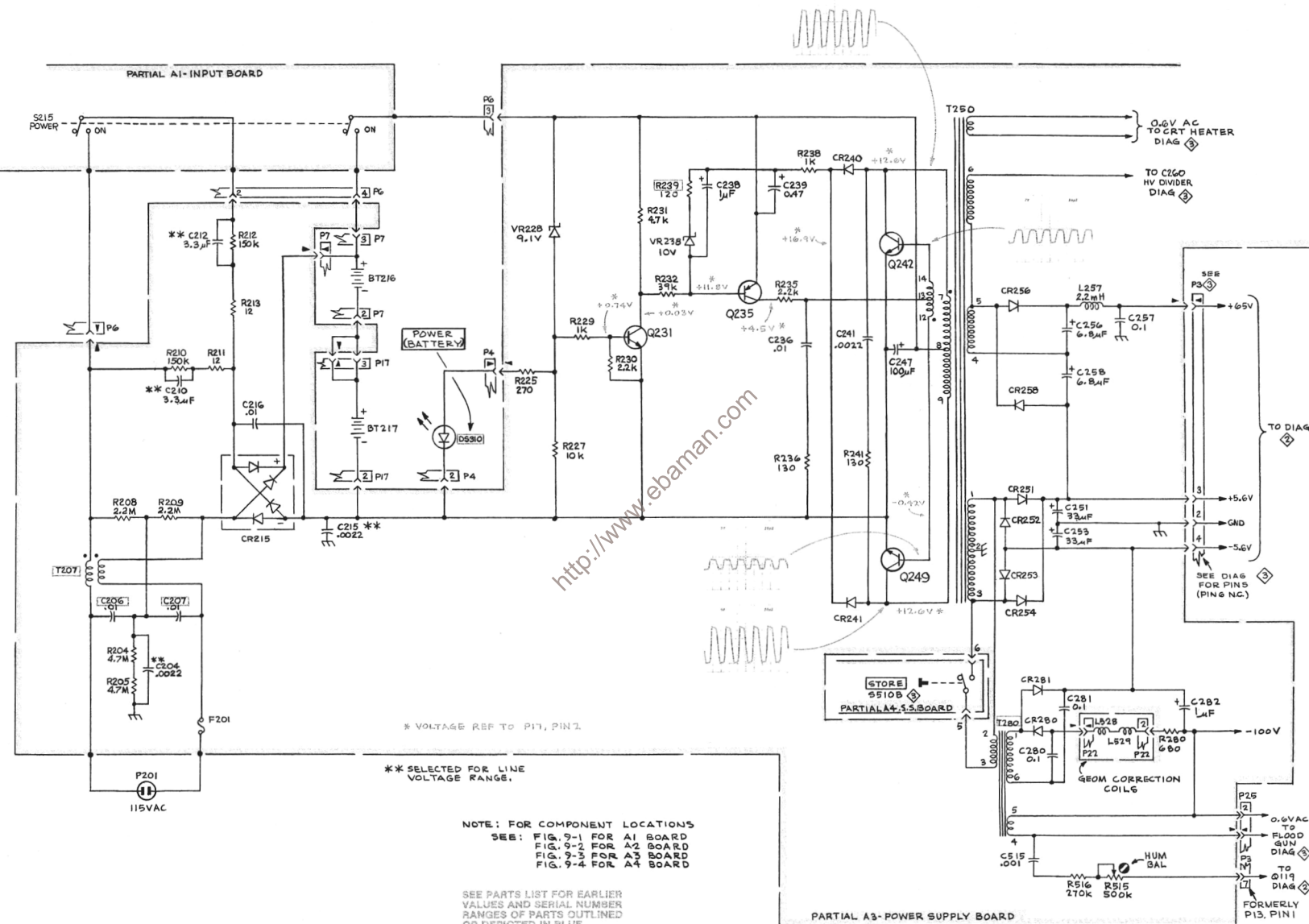

** VOLTAGE REF TO P17, PIN 1

** SELECTED FOR LINE VOLTAGE RANGE.

NOTE: FOR COMPONENT LOCATIONS
 SEE: FIG. 9-1 FOR A1 BOARD
 FIG. 9-2 FOR A2 BOARD
 FIG. 9-3 FOR A3 BOARD
 FIG. 9-4 FOR A4 BOARD

SEE PARTS LIST FOR EARLIER
 VALUES AND SERIAL NUMBER
 RANGES OF PARTS OUTLINED
 OR DEPICTED IN BLUE.

PARTIAL A3-POWER SUPPLY BOARD

FORMERLY P13, PIN 1

REPLACEABLE ELECTRICAL PARTS

PARTS ORDERING INFORMATION

Replacement parts are available from or through your local Tektronix, Inc. Field Office or representative.

Changes to Tektronix instruments are sometimes made to accommodate improved components as they become available, and to give you the benefit of the latest circuit improvements developed in our engineering department. It is therefore important, when ordering parts, to include the following information in your order: Part number, instrument type or number, serial number, and modification number if applicable.

If a part you have ordered has been replaced with a new or improved part, your local Tektronix, Inc. Field Office or representative will contact you concerning any change in part number.

Change information, if any, is located at the rear of this manual.

SPECIAL NOTES AND SYMBOLS

X000 Part first added at this serial number
00X Part removed after this serial number

ITEM NAME

In the Parts List, an Item Name is separated from the description by a colon (:). Because of space limitations, an Item Name may sometimes appear as incomplete. For further Item Name identification, the U.S. Federal Cataloging Handbook H6-1 can be utilized where possible.

ABBREVIATIONS

ACTR	ACTUATOR	PLSTC	PLASTIC
ASSY	ASSEMBLY	QTZ	QUARTZ
CAP	CAPACITOR	RECP	RECEPTACLE
CER	CERAMIC	RES	RESISTOR
CKT	CIRCUIT	RF	RADIO FREQUENCY
COMP	COMPOSITION	SEL	SELECTED
CONN	CONNECTOR	SEMICOND	SEMICONDUCTOR
ELCTLT	ELECTROLYTIC	SENS	SENSITIVE
ELEC	ELECTRICAL	VAR	VARIABLE
INCAND	INCANDESCENT	WW	WIREWOUND
LED	LIGHT EMITTING DIODE	XFMR	TRANSFORMER
NONWIR	NON WIREWOUND	XTAL	CRYSTAL

CROSS INDEX—MFR. CODE NUMBER TO MANUFACTURER

Mfr. Code	Manufacturer	Address	City, State, Zip
01121	ALLEN-BRADLEY COMPANY	1201 2ND STREET SOUTH	MILWAUKEE, WI 53204
01295	TEXAS INSTRUMENTS, INC., SEMICONDUCTOR GROUP	P O BOX 5012, 13500 N CENTRAL EXPRESSWAY	DALLAS, TX 75222
03508	GENERAL ELECTRIC COMPANY, SEMI-CONDUCTOR PRODUCTS DEPARTMENT	ELECTRONICS PARK	SYRACUSE, NY 13201
03888	KDI PYROFILM CORPORATION	60 S JEFFERSON ROAD	WHIPPANY, NJ 07981
04713	MOTOROLA, INC., SEMICONDUCTOR PROD. DIV.	5005 E MCDOWELL RD, PO BOX 20923	PHOENIX, AZ 85036
07263	FAIRCHILD SEMICONDUCTOR, A DIV. OF FAIRCHILD CAMERA AND INSTRUMENT CORP.	464 ELLIS STREET	MOUNTAIN VIEW, CA 94042
11237	CTS KEENE, INC.	3230 RIVERSIDE AVE.	PASO ROBLES, CA 93446
14433	ITT SEMICONDUCTORS	3301 ELECTRONICS WAY P O BOX 3049	WEST PALM BEACH, FL 33402
14752	ELECTRO CUBE INC.	1710 S. DEL MAR AVE.	SAN GABRIEL, CA 91776
16546	U.S. CAPACITOR CORP/CENTRALAB ELECTRONICS DIV.	4561 COLORADO	LOS ANGELES, CA 90039
27014	NATIONAL SEMICONDUCTOR CORP.	2900 SEMICONDUCTOR DR.	SANTA CLARA, CA 95051
32997	BOURNS, INC., TRIMPOT PRODUCTS DIV.	1200 COLUMBIA AVE.	RIVERSIDE, CA 92507
51642	CENTRE ENGINEERING INC.	2820 E COLLEGE AVENUE	STATE COLLEGE, PA 16801
56289	SPRAGUE ELECTRIC CO.		NORTH ADAMS, MA 01247
71450	CTS CORP.	905 N. WEST BLVD	ELKHART, IN 46514
72982	ERIE TECHNOLOGICAL PRODUCTS, INC.	644 W. 12TH ST.	ERIE, PA 16512
73138	BECKMAN INSTRUMENTS, INC., HELIPOT DIV.	2500 HARBOR BLVD.	FULLERTON, CA 92634
75915	LITTELFUSE, INC.	800 E. NORTHWEST HWY	DES PLAINES, IL 60016
76493	BELL INDUSTRIES, INC., MILLER, J. W., DIV.	19070 REYES AVE., P O BOX 5825	COMPTON, CA 90224
79727	C-W INDUSTRIES	550 DAVISVILLE RD., P O BOX 96	WARMINISTER, PA 18974
80009	TEKTRONIX, INC.	P O BOX 500	BEAVERTON, OR 97077
80031	ELECTRA-MIDLAND CORP., MEPCO DIV.	22 COLUMBIA ROAD	MORRISTOWN, NJ 07960
84411	TRW ELECTRONIC COMPONENTS, TRW CAPACITORS	112 W. FIRST ST.	OGALLALA, NE 69153
90201	MALLORY CAPACITOR CO., DIV. OF P. R. MALLORY AND CO., INC.	3029 E. WASHINGTON STREET P. O. BOX 372	INDIANAPOLIS, IN 46206
91637	DALE ELECTRONICS, INC.	P. O. BOX 609	COLUMBUS, NE 68601

<http://www.ebam.com>

Ckt No.	Tektronix Part No.	Serial/Model No. Eff	Dscont	Name & Description	Mfr Code	Mfr Part Number
A1	670-2353-01	B010100	B055611	CKT BOARD ASSY: INPUT	80009	670-2353-01
A1	670-2353-03	B055612	B089999	CKT BOARD ASSY: INPUT	80009	670-2353-03
A1	670-2353-05	B090000	B099999	CKT BOARD ASSY: INPUT	80009	670-2353-05
A1	670-2353-07	B100000		CKT BOARD ASSY: INPUT	80009	670-2353-07
A2	670-1505-02			CKT BOARD ASSY: AMPLIFIER	80009	670-1505-02
A3	670-2741-00	B010100	B049999	CKT BOARD ASSY: POWER SUPPLY	80009	670-2741-00
A3	670-2741-11	B050000		CKT BOARD ASSY: POWER SUPPLY	80009	670-2741-11
A3	670-2741-21			CKT BOARD ASSY: POWER SUPPLY (OPTION 1 ONLY)	80009	670-2741-21
A3	670-2741-31			CKT BOARD ASSY: POWER SUPPLY (OPTION 2 ONLY)	80009	670-2741-31
A4	670-2676-00	B010100	B059999	CKT BOARD ASSY: SINGLE SWEEP	80009	670-2676-00
A4	670-2676-01	B060000		CKT BOARD ASSY: SINGLE SWEEP	80009	670-2676-01
BT216	146-0033-00			BATTERY ASSY: 2 SETS OF 5	80009	146-0033-00
BT217	146-0033-00			BATTERY ASSY: 2 SETS OF 5	80009	146-0033-00
C101	283-0111-00			CAP., FXD, CER DI: 0.1UF, 20%, 50V	72982	8121-N088Z5U104M
C103	283-0111-00			CAP., FXD, CER DI: 0.1UF, 20%, 50V	72982	8121-N088Z5U104M
C104	281-0591-00	B010100	B066826	CAP., FXD, CER DI: 5600PF, 20%, 200V	72982	393001Z5V0562Z
C104	283-0180-00	B066827		CAP., FXD, CER DI: 5600PF, 20%, 200V	72982	8121N204 E 562M
C113	283-0111-00			CAP., FXD, CER DI: 0.1UF, 20%, 50V	72982	8121-N088Z5U104M
C115	283-0111-00			CAP., FXD, CER DI: 0.1UF, 20%, 50V	72982	8121-N088Z5U104M
C125	290-0524-00			CAP., FXD, ELCTLT: 4.7UF, 20%, 10V	90201	TDC475M010EL
C127	290-0524-00			CAP., FXD, ELCTLT: 4.7UF, 20%, 10V	90201	TDC475M010EL
C129	290-0522-00			CAP., FXD, ELCTLT: 1UF, 20%, 50V	56289	196D105X0050HA1
C150	281-0591-00	B010100	B066826	CAP., FXD, CER DI: 5600PF, 20%, 200V	72982	393001Z5V0562Z
C150	283-0180-00	B066827		CAP., FXD, CER DI: 5600PF, 20%, 200V	72982	8121N204 E 562M
C153	281-0591-00	B010100	B066826	CAP., FXD, CER DI: 5600PF, 20%, 200V	72982	393001Z5V0562Z
C153	283-0180-00	B066827		CAP., FXD, CER DI: 5600PF, 20%, 200V	72982	8121N204 E 562M
C204	283-0263-00			CAP., FXD, CER DI: 0.0022UF, 20%, 3000V (NOMINAL VALUE, SELECTED FOR LINE VOLTAGE AND FREQUENCY. SEE OPTION INFORMATION)	56289	33C319
C204	283-0279-00			CAP., FXD, CER DI: 0.001UF, 20%, 3000V (NOMINAL VALUE, SELECTED FOR LINE VOLTAGE AND FREQUENCY. SEE OPT INFORMATION. OPT 1 ONLY)	56289	55C153
C206	283-0057-00	B010100	B051099	CAP., FXD, CER DI: 0.1UF, +80-20%, 200V	56289	274C10
C206	285-1065-00	B051100		CAP., FXD, PLSTC: 0.01UF, 20%, 600V	14752	230B1F103
C207	283-0057-00	B010100	B051099	CAP., FXD, CER DI: 0.1UF, +80-20%, 200V	56289	274C10
C207	281-1065-00	B051100		CAP., FXD, PLSTC: 0.01UF, 20%, 600V	14752	230B1F103
C210	285-0925-00			CAP., FXD, PLSTC: 3.3UF, 10%, 200V (NOMINAL VALUE, SELECTED FOR LINE VOLTAGE AND FREQUENCY. SEE OPTION INFORMATION)	84411	TEK121-33592
C210	285-0933-00			CAP., FXD, PLSTC: 2UF, 10%, 400V (NOMINAL VALUE, SELECTED FOR LINE VOLTAGE AND FREQUENCY. SEE OPT INFORMATION. OPT 1 ONLY)	14752	A-1480
C210	285-0935-00			CAP., FXD, PLSTC: 4.4UF, 10%, 200V (NOMINAL VALUE, SELECTED FOR LINE VOLTAGE AND FREQUENCY. SEE OPT INFORMATION. OPT 2 ONLY)	56289	430P179
C212	285-0925-00			CAP., FXD, PLSTC: 3.3UF, 10%, 200V (NOMINAL VALUE, SELECTED FOR LINE VOLTAGE AND FREQUENCY. SEE OPTION INFORMATION)	84411	TEK121-33592
C212	285-0933-00			CAP., FXD, PLSTC: 2UF, 10%, 400V (NOMINAL VALUE, SELECTED FOR LINE VOLTAGE AND FREQUENCY. SEE OPT INFORMATION. OPT 1 ONLY)	14752	A-1480
C212	285-0935-00			CAP., FXD, PLSTC: 4.4UF, 10%, 200V (NOMINAL VALUE, SELECTED FOR LINE VOLTAGE AND FREQUENCY. SEE OPT INFORMATION. OPT 2 ONLY)	56289	430P179

Replaceable Electrical Parts—214 Service

Ckt No.	Tektronix Part No.	Serial/Model No. Eff	Dscont	Name & Description	Mfr Code	Mfr Part Number
C215	283-0263-00			CAP., FXD, CER DI:0.0022UF, 20%, 3000V (NOMINAL VALUE, SELECTED FOR LINE VOLTAGE AND FREQUENCY. SEE OPTION INFORMATION)	56289	33C319
C215	283-0279-00			CAP., FXD, CER DI:0.001UF, 20%, 3000V (NOMINAL VALUE, SELECTED FOR LINE VOLTAGE AND FREQUENCY. SEE OPT INFORMATION. OPT 1 ONLY)	56289	55C153
C216	283-0068-00			CAP., FXD, CER DI:0.01UF, +100-0%, 500V	56289	19C241
C236	283-0003-00			CAP., FXD, CER DI:0.01UF, +80-20%, 150V	72982	855-558Z5U-103Z
C238	290-0534-00			CAP., FXD, ELCTLT:1UF, 20%, 35V	56289	196D105X0035HA1
C239	290-0283-00			CAP., FXD, ELCTLT:0.47UF, 10%, 35V	56289	162D474X9035BC2
C241	283-0028-00			CAP., FXD, CER DI:0.0022UF, 20%, 50V	56289	19C606
C247	290-0519-00			CAP., FXD, ELCTLT:100UF, 20%, 20V	90201	TDC107M020WLD
C251	290-0535-01			CAP., FXD, ELCTLT:33UF, 20%, 10V	56289	196D336X0010KA1
C253	290-0535-01			CAP., FXD, ELCTLT:33UF, 20%, 10V	56289	196D336X0010KA1
C256	290-0517-00			CAP., FXD, ELCTLT:6.8UF, 20%, 35V	56289	196D685X0035KA1
C257	283-0057-00			CAP., FXD, CER DI:0.1UF, +80-20%, 200V	56289	274C10
C258	290-0517-00			CAP., FXD, ELCTLT:6.8UF, 20%, 35V	56289	196D685X0035KA1
C260	283-0068-00			CAP., FXD, CER DI:0.01UF, +100-0%, 500V	56289	19C241
C261	283-0177-00			CAP., FXD, CER DI:1UF, +80-20%, 25V	56289	273C5
C262	283-0068-00			CAP., FXD, CER DI:0.01UF, +100-0%, 500V	56289	19C241
C263	283-0068-00			CAP., FXD, CER DI:0.01UF, +100-0%, 500V	56289	19C241
C264	283-0068-00			CAP., FXD, CER DI:0.01UF, +100-0%, 500V	56289	19C241
C265	283-0068-00			CAP., FXD, CER DI:0.01UF, +100-0%, 500V	56289	19C241
C266	283-0068-00			CAP., FXD, CER DI:0.01UF, +100-0%, 500V	56289	19C241
C267	283-0068-00			CAP., FXD, CER DI:0.01UF, +100-0%, 500V	56289	19C241
C268	283-0068-00			CAP., FXD, CER DI:0.01UF, +100-0%, 500V	56289	19C241
C269	283-0001-00			CAP., FXD, CER DI:0.005UF, +100-0%, 500V	72982	831-559E502P
C270	283-0111-00			CAP., FXD, CER DI:0.1UF, 20%, 50V	72982	8121-N088Z5U104M
C273	283-0105-00			CAP., FXD, CER DI:0.01UF, +80-20%, 2000V	56289	41C316
C280	283-0111-00			CAP., FXD, CER DI:0.1UF, 20%, 50V	72982	8121-N088Z5U104M
C281	283-0111-00			CAP., FXD, CER DI:0.1UF, 20%, 50V	72982	8121-N088Z5U104M
C282	290-0164-00			CAP., FXD, ELCTLT:1UF, +50-10%, 150V	56289	500D105F150BA7
C301	285-0697-06			CAP., FXD, PLSTC:0.1UF, +5-15%, 600V	80009	285-0697-06
C306B,	307-0307-01			NTWK, HYB CKT:	80009	307-0307-01
C306D, F	-----			(FURNISHED AS A UNIT WITH R306A-F)		
C307	281-0178-00			CAP., VAR, PLSTC:1-3.5PF, 500V	80031	2805D013R5BH02F0
C308	281-0178-00			CAP., VAR, PLSTC:1-3.5PF, 500V	80031	2805D013R5BH02F0
C309	281-0178-00			CAP., VAR, PLSTC:1-3.5PF, 500V	80031	2805D013R5BH02F0
C313	283-0000-00			CAP., FXD, CER DI:0.001UF, +100-0%, 500V	72982	831-516E102P
C321	283-0168-00			CAP., FXD, CER DI:12PF, 5%, 100V	72982	8101B121C0G0120J
C323	281-0645-00	B010100	B052541	CAP., FXD, CER DI:8.2PF, +/-0.25PF, 500V	72982	374018C0H0829C
C323	281-0645-00	B052542		CAP., FXD, CER DI:8.2PF, +/-0.25PF, 500V	72982	374018C0H0829C
C327	283-0111-00			CAP., FXD, CER DI:0.1UF, 20%, 50V	72982	8121-N088Z5U104M
C329	290-0530-00			CAP., FXD, ELCTLT:68UF, 20%, 6V	90201	TDC686M006NLF
C348	283-0084-00			CAP., FXD, CER DI:270PF, 5%, 1000V	72982	838-533B271J
C349	283-0076-00			CAP., FXD, CER DI:27PF, 10%, 500V	56289	40C287A2
C353	290-0524-00			CAP., FXD, ELCTLT:4.7UF, 20%, 10V	90201	TDC475M010EL
C362	295-0144-00			CAP SET, MATCHED:1UF, 0.001UF, MATCHED	84411	TEK101-0009R5
C363	-----			(C362, C363, C364, INDIVIDUAL TIMING CAPACITORS		
C364	-----			IN THIS ASSY MUST BE ORDERED BY THE 9-DIGIT		
	-----			PART NUMBER, LETTER SUFFIX AND TOLERANCE		
	-----			PRINTED ON THE TIMING CAPACITORS IN THE		
	-----			ASSEMBLY. EXAMPLE: 285-XXXX-XX F -)		
C368	283-0204-00			CAP., FXD, CER DI:0.01UF, 20%, 50V	72982	8121N061Z5U0103M
C370	283-0251-00	XB055612		CAP., FXD, CER DI:87 PF, 5%, 100V	72982	8121B145C0G0870J
C371	290-0523-00			CAP., FXD, ELCTLT:2.2UF, 20%, 20V	56289	196D225X0020HA1
C372	-----			(PART OF CIRCUIT BOARD)		
C373	283-0068-00			CAP., FXD, CER DI:0.01UF, +100-0%, 500V	56289	19C241

Ckt No.	Tektronix Part No.	Serial/Model No. Eff	Dscont	Name & Description	Mfr Code	Mfr Part Number
C374	290-0523-00			CAP., FXD, ELCTLT: 2.2UF, 20%, 20V	56289	196D225X0020HA1
C376	290-0534-00			CAP., FXD, ELCTLT: 1UF, 20%, 35V	56289	196D105X0035HA1
C378	283-0068-00			CAP., FXD, CER DI: 0.01UF, +100-0%, 500V	56289	19C241
C381	283-0000-00			CAP., FXD, CER DI: 0.001UF, +100-0%, 500V	72982	831-516E102P
C382	283-0000-00			CAP., FXD, CER DI: 0.001UF, +100-0%, 500V	72982	831-516E102P
C383	283-0111-00			CAP., FXD, CER DI: 0.1UF, 20%, 50V	72982	8121-N08825U104M
C385	283-0103-00			CAP., FXD, CER DI: 180PF, 5%, 500V	56289	40C638
C392	283-0087-00			CAP., FXD, CER DI: 300PF, 10%, 1000V	56289	403637
C395	283-0013-00			CAP., FXD, CER DI: 0.01UF, +100-0%, 1000V	56289	33C29A7
C401	285-0697-06			CAP., FXD, PLSTC: 0.1UF, +5-15%, 600V	80009	285-0697-06
C406B, C406D,F	307-0307-01 -----			NTWK, HYB CKT: (FURNISHED AS A UNIT WITH R406A-F)	80009	307-0307-01
C407	281-0178-00			CAP., VAR, PLSTC: 1-3.5PF, 500V	80031	2805D013R5BH02F0
C408	281-0178-00			CAP., VAR, PLSTC: 1-3.5PF, 500V	80031	2805D013R5BH02F0
C409	281-0178-00			CAP., VAR, PLSTC: 1-3.5PF, 500V	80031	2805D013R5BH02F0
C413	283-0000-00			CAP., FXD, CER DI: 0.001UF, +100-0%, 500V	72982	831-516E102P
C421	283-0168-00			CAP., FXD, CER DI: 12PF, 5%, 100V	72982	8101B121COG0120J
C423	281-0612-00	B010100	B052541	CAP., FXD, CER DI: 5.6PF, +/-0.5PF, 500V	72982	374-001COH0569D
C423	281-0612-00	B052542		CAP., FXD, CER DI: 5.6PF, +/-0.5PF, 500V	72982	374-001COH0569D
C453	290-0524-00			CAP., FXD, ELCTLT: 4.7UF, 20%, 10V	90201	TDC475M010EL
C491	290-0535-00			CAP., FXD, ELCTLT: 33UF, 20%, 10V	56289	196D336X0010KA1
C493	290-0535-00			CAP., FXD, ELCTLT: 33UF, 20%, 10V	56289	196D336X0010KA1
C508	283-0178-00			CAP., FXD, CER DI: 0.1UF, +80-20%, 100V	72982	8131N145651 104Z
C510	283-0198-00			CAP., FXD, CER DI: 0.22UF, 20%, 50V	72982	8121N083Z5U0224M
C512	283-0208-00			CAP., FXD, CER DI: 0.22UF, 10%, 200V	72982	8151N230 C 224K
C515	283-0067-00			CAP., FXD, CER DI: 0.001UF, 10%, 200V	72982	835-515B102K
C530	283-0197-00	B010100	B059999	CAP., FXD, CER DI: 470PF, 5%, 100V	72982	8121N075COG0471J
C530	283-0176-00	B060000		CAP., FXD, CER DI: 0.0022UF, 20%, 50V	72982	8121B058X7R0222M
C535	283-0268-00			CAP., FXD, CER DI: 0.015UF, 10%, 50V	72982	8121N083X7R0153K
C536	283-0139-00			CAP., FXD, CER DI: 150PF, 20%, 50V	51642	W100-050-X5F151M
C537	283-0326-00			CAP., FXD, CER DI: 0.082UF, 10%, 50V	16546	CW20C823K
CR215	152-0488-00			SEMICONV DEVICE: SILICON, 200V, 1500MA	04713	3N55 FAMILY
CR240	152-0141-02			SEMICONV DEVICE: SILICON, 30V, 150MA	01295	1N4152R
CR241	152-0141-02			SEMICONV DEVICE: SILICON, 30V, 150MA	01295	1N4152R
CR251	152-0141-02			SEMICONV DEVICE: SILICON, 30V, 150MA	01295	1N4152R
CR252	152-0141-02			SEMICONV DEVICE: SILICON, 30V, 150MA	01295	1N4152R
CR253	152-0141-02			SEMICONV DEVICE: SILICON, 30V, 150MA	01295	1N4152R
CR254	152-0141-02			SEMICONV DEVICE: SILICON, 30V, 150MA	01295	1N4152R
CR256	152-0333-00			SEMICONV DEVICE: SILICON, 55V, 200MA	07263	FDH-6012
CR258	152-0333-00			SEMICONV DEVICE: SILICON, 55V, 200MA	07263	FDH-6012
CR261	152-0107-00	B010100	B029999	SEMICONV DEVICE: SILICON, 400V, 400MA	01295	G727
CR261	152-0107-03	B030000		SEMICONV DEVICE: SILICON, 375V, 400MA, SEL	80009	152-0107-03
CR262	152-0107-00	B010100	B029999	SEMICONV DEVICE: SILICON, 400V, 400MA	01295	G727
CR262	152-0107-03	B030000		SEMICONV DEVICE: SILICON, 375V, 400MA, SEL	80009	152-0107-03
CR263	152-0107-00	B010100	B029999	SEMICONV DEVICE: SILICON, 400V, 400MA	01295	G727
CR263	152-0107-03	B030000		SEMICONV DEVICE: SILICON, 375V, 400MA, SEL	80009	152-0107-03
CR264	152-0107-00	B010100	B029999	SEMICONV DEVICE: SILICON, 400V, 400MA	01295	G727
CR264	152-0107-03	B030000		SEMICONV DEVICE: SILICON, 375V, 400MA, SEL	80009	152-0107-03
CR265	152-0107-00	B010100	B029999	SEMICONV DEVICE: SILICON, 400V, 400MA	01295	G727
CR265	152-0107-03	B030000		SEMICONV DEVICE: SILICON, 375V, 400MA, SEL	80009	152-0107-03
CR266	152-0107-00	B010100	B029999	SEMICONV DEVICE: SILICON, 400V, 400MA	01295	G727
CR266	152-0107-03	B030000		SEMICONV DEVICE: SILICON, 375V, 400MA, SEL	80009	152-0107-03
CR267	152-0107-00	B010100	B029999	SEMICONV DEVICE: SILICON, 400V, 400MA	01295	G727
CR267	152-0107-03	B030000		SEMICONV DEVICE: SILICON, 375V, 400MA, SEL	80009	152-0107-03
CR268	152-0107-00	B010100	B029999	SEMICONV DEVICE: SILICON, 400V, 400MA	01295	G727
CR268	152-0107-03	B030000		SEMICONV DEVICE: SILICON, 375V, 400MA, SEL	80009	152-0107-03

Replaceable Electrical Parts—214 Service

Ckt No.	Tektronix Part No.	Serial/Model No. Eff	Dscont	Name & Description	Mfr Code	Mfr Part Number
CR280	152-0107-00	B010100	B040712	SEMICON D DEVICE: SILICON, 400V, 400MA	01295	G727
CR280	152-0107-03	B040713		SEMICON D DEVICE: SILICON, 375V, 400MA, SEL	80009	152-0107-03
CR281	152-0107-00	B010100	B040712	SEMICON D DEVICE: SILICON, 400V, 400MA	01295	G727
CR281	152-0107-03	B040713		SEMICON D DEVICE: SILICON, 375V, 400MA, SEL	80009	152-0107-03
CR313	152-0246-00			SEMICON D DEVICE: SW, SI, 40V, 200MA	03508	DE140
CR342	152-0141-02			SEMICON D DEVICE: SILICON, 30V, 150MA	01295	1N4152R
CR343	152-0141-02			SEMICON D DEVICE: SILICON, 30V, 150MA	01295	1N4152R
CR346	152-0141-02			SEMICON D DEVICE: SILICON, 30V, 150MA	01295	1N4152R
CR383	152-0141-02			SEMICON D DEVICE: SILICON, 30V, 150MA	01295	1N4152R
CR389	152-0141-02			SEMICON D DEVICE: SILICON, 30V, 150MA	01295	1N4152R
CR413	152-0246-00			SEMICON D DEVICE: SW, SI, 40V, 200MA	03508	DE140
CR446	152-0141-02			SEMICON D DEVICE: SILICON, 30V, 150MA	01295	1N4152R
CR509	152-0141-02			SEMICON D DEVICE: SILICON, 30V, 150MA	01295	1N4152R
CR511	152-0107-00			SEMICON D DEVICE: SILICON, 400V, 400MA	01295	G727
CR512	152-0107-00			SEMICON D DEVICE: SILICON, 400V, 400MA	01295	G727
CR513	152-0141-02			SEMICON D DEVICE: SILICON, 30V, 150MA	01295	1N4152R
CR514	152-0107-00			SEMICON D DEVICE: SILICON, 400V, 400MA	01295	G727
CR522	152-0141-02			SEMICON D DEVICE: SILICON, 30V, 150MA	01295	1N4152R
CR524	152-0141-02	XB050000		SEMICON D DEVICE: SILICON, 30V, 150MA	01295	1N4152R
CR526	152-0141-02	XB050000		SEMICON D DEVICE: SILICON, 30V, 150MA	01295	1N4152R
CR528	152-0141-02	XB050000		SEMICON D DEVICE: SILICON, 30V, 150MA	01295	1N4152R
CR530	152-0141-02			SEMICON D DEVICE: SILICON, 30V, 150MA	01295	1N4152R
DS310	150-1004-02	B010100	B054579	LT EMITTING DIO: RED, 15MA, W/HOLDER & LEADS	80009	150-1004-02
DS310	150-1031-01	B054580		LAMP, LED: W/DIODE, WIRE AND CONN	80009	150-1031-01
DS320	150-1061-00	XB090000		LT EMITTING DIO: RED, 660NM, 50MA MAX	27014	SJ62775
DS420	150-1061-00	XB090000		LT EMITTING DIO: RED, 660NM, 50MA MAX	27014	SJ62775
DS535	150-1004-03	B010100	B054579	LT EMITTING DIO: RED, 15MA, W/HOLDER & LEADS	80009	150-1004-03
DS535	150-1031-02	B054580		LAMP, LED: W/DIODE, WIRE AND CONN	80009	150-1031-02
F201	159-0121-00			FUSE, CARTRIDGE: DIN, 0.4A, 250V, 5 SEC	75915	212.400
J348	129-0398-00			POST, CONTACT: FOR JACK TIP	80009	129-0398-00
J349	129-0398-00			POST, CONTACT: FOR JACK TIP	80009	129-0398-00
L108	108-0691-00			COIL, RF: 1.8MH	76493	02279
L111	108-0691-00			COIL, RF: 1.8MH	76493	02279
L257	108-0654-00			COIL, RF: 2.2MH	76493	01872
L300	-----			(FURNISHED AS A UNIT WITH CRT)		
L528	108-0756-00			COIL, TUBE DEFLE: GEOMETRY CORRECTION	80009	108-0756-00
L529	108-0756-00			COIL, TUBE DEFLE: GEOMETRY CORRECTION	80009	108-0756-00
Q107	151-0432-00			TRANSISTOR: SILICON, NPN	80009	151-0432-00
Q110	151-0432-00			TRANSISTOR: SILICON, NPN	80009	151-0432-00
Q119	151-0432-00			TRANSISTOR: SILICON, NPN	80009	151-0432-00
Q122	151-0432-00			TRANSISTOR: SILICON, NPN	80009	151-0432-00
Q134	151-0432-00			TRANSISTOR: SILICON, NPN	80009	151-0432-00
Q231	151-0341-00			TRANSISTOR: SILICON, NPN	07263	S040065
Q235	151-0220-00			TRANSISTOR: SILICON, PNP	07263	S036228
Q242	151-0334-00			TRANSISTOR: SILICON, NPN	80009	151-0334-00
Q249	151-0334-00			TRANSISTOR: SILICON, NPN	80009	151-0334-00
Q314	151-1072-00	B010100	B089999	TRANSISTOR: SILICON, JFE, P-CHAN, DUAL	80009	151-1072-00
Q314	151-1057-00	B090000		TRANSISTOR: SILICON, FE, N-CHANNEL, DUAL	80009	151-1057-00
Q326	151-0341-00			TRANSISTOR: SILICON, NPN	07263	S040065
Q328	151-0341-00			TRANSISTOR: SILICON, NPN	07263	S040065
Q380	151-0341-00			TRANSISTOR: SILICON, NPN	07263	S040065
Q388	151-0504-00			TRANSISTOR: SILICON, N-CHAN, UNI JUNCTION	04713	2N4851
Q392	151-0432-00			TRANSISTOR: SILICON, NPN	80009	151-0432-00
Q414	151-1072-00	B010100	B089999	TRANSISTOR: SILICON, JFE, P-CHAN, DUAL	80009	151-1072-00
Q414	151-1057-00	B090000		TRANSISTOR: SILICON, FE, N-CHANNEL, DUAL	80009	151-1057-00

Ckt No.	Tektronix Part No.	Serial/Model No. Eff	Dscont	Name & Description	Mfr Code	Mfr Part Number
Q454	151-0341-00			TRANSISTOR:SILICON,NPN	07263	S040065
Q502	151-0190-00	B010100	B051336	TRANSISTOR:SILICON,NPN	07263	S032677
Q502	151-0432-00	B051337		TRANSISTOR:SILICON,NPN	80009	151-0432-00
Q505	151-0347-00			TRANSISTOR:SILICON,NPN	56289	2N5551
Q510	151-0292-00	B010100	B049999	TRANSISTOR:SILICON,NPN	80009	151-0292-00
Q510	151-0444-00	B050000		TRANSISTOR:SILICON,NPN	80009	151-0444-00
Q512	151-0292-00	B010100	B049999	TRANSISTOR:SILICON,NPN	80009	151-0292-00
Q512	151-0444-00	B050000		TRANSISTOR:SILICON,NPN	80009	151-0444-00
Q520	151-0350-00			TRANSISTOR:SILICON,PNP	04713	SPS6700
Q521	151-0410-00			TRANSISTOR:SILICON,PNP	80009	151-0410-00
Q530	151-0190-00			TRANSISTOR:SILICON,NPN	07263	S032677
Q532	151-0342-00			TRANSISTOR:SILICON,PNP	07263	S035928
Q535	151-0341-00			TRANSISTOR:SILICON,NPN	07263	S040065
R101	311-1235-00			RES.,VAR, NONWIR:100K OHM,20%,0.50W	32997	3386F-T04-104
R105	321-0218-00			RES.,FXD,FILM:1.82K OHM,1%,0.125W	91637	MFF1816G18200F
R106	316-0471-00			RES.,FXD,CMPSN:470 OHM,10%,0.25W	01121	CB4711
R107	322-0331-00			RES.,FXD,FILM:27.4K OHM,1%,0.25W	01121	OBD
R108	316-0223-00			RES.,FXD,CMPSN:22K OHM,10%,0.25W	01121	CB2231
R109	316-0471-00			RES.,FXD,CMPSN:470 OHM,10%,0.25W	01121	CB4711
R110	322-0331-00			RES.,FXD,FILM:27.4K OHM,1%,0.25W	01121	OBD
R111	316-0223-00			RES.,FXD,CMPSN:22K OHM,10%,0.25W	01121	CB2231
R117	321-0260-00			RES.,FXD,FILM:4.99K OHM,1%,0.125W	91637	MFF1816G49900F
R118	316-0471-00			RES.,FXD,CMPSN:470 OHM,10%,0.25W	01121	CB4711
R119	321-0373-00			RES.,FXD,FILM:75K OHM,1%,0.125W	91637	MFF1816G75001F
R121	316-0471-00			RES.,FXD,CMPSN:470 OHM,10%,0.25W	01121	CB4711
R122	321-0373-00			RES.,FXD,FILM:75K OHM,1%,0.125W	91637	MFF1816G75001F
R125	316-0150-00			RES.,FXD,CMPSN:15 OHM,10%,0.25W	01121	CB1501
R127	316-0150-00			RES.,FXD,CMPSN:15 OHM,10%,0.25W	01121	CB1501
R129	321-0169-00			RES.,FXD,FILM:562 OHM,1%,0.125W	91637	MFF1816G562R0F
R132	315-0123-00			RES.,FXD,CMPSN:12K OHM,5%,0.25W	01121	CB1235
R134	321-0354-00			RES.,FXD,FILM:47.5K OHM,1%,0.125W	91637	MFF1816G47501F
R135	321-0377-00			RES.,FXD,FILM:82.5K OHM,1%,0.125W	91637	MFF1816G82501F
R136	315-0332-00			RES.,FXD,CMPSN:3.3K OHM,5%,0.25W	01121	CB3325
R137	315-0202-00			RES.,FXD,CMPSN:2K OHM,5%,0.25W	01121	CB2025
R141	311-1232-00			RES.,VAR, NONWIR:50K OHM,20%,0.50W	32997	3386F-T04-503
R150	316-0470-00			RES.,FXD,CMPSN:47 OHM,10%,0.25W	01121	CB4701
R151	315-0153-00			RES.,FXD,CMPSN:15K OHM,5%,0.25W	01121	CB1535
R153	316-0470-00			RES.,FXD,CMPSN:47 OHM,10%,0.25W	01121	CB4701
R154	315-0473-00			RES.,FXD,CMPSN:47K OHM,5%,0.25W	01121	CB4735
R155	316-0392-00			RES.,FXD,CMPSN:3.9K OHM,10%,0.25W	01121	CB3921
R204	316-0475-00			RES.,FXD,CMPSN:4.7M OHM,10%,0.25W	01121	CB4751
R205	316-0475-00			RES.,FXD,CMPSN:4.7M OHM,10%,0.25W	01121	CB4751
R208	316-0225-00			RES.,FXD,CMPSN:2.2M OHM,10%,0.25W	01121	CB2251
R209	316-0225-00			RES.,FXD,CMPSN:2.2M OHM,10%,0.25W	01121	CB2251
R210	302-0154-00			RES.,FXD,CMPSN:150K OHM,10%,0.50W	01121	EB1541
R211	302-0120-00			RES.,FXD,CMPSN:12 OHM,10%,0.50W	01121	EB1201
R212	302-0154-00			RES.,FXD,CMPSN:150K OHM,10%,0.50W	01121	EB1541
R213	302-0120-00			RES.,FXD,CMPSN:12 OHM,10%,0.50W	01121	EB1201
R225	315-0271-00			RES.,FXD,CMPSN:270 OHM,5%,0.25W	01121	CB2715
R227	315-0103-00			RES.,FXD,CMPSN:10K OHM,5%,0.25W	01121	CB1035
R229	315-0102-00			RES.,FXD,CMPSN:1K OHM,5%,0.25W	01121	CB1025
R230	315-0222-00			RES.,FXD,CMPSN:2.2K OHM,5%,0.25W	01121	CB2225
R231	315-0472-00			RES.,FXD,CMPSN:4.7K OHM,5%,0.25W	01121	CB4725
R232	315-0393-00			RES.,FXD,CMPSN:39K OHM,5%,0.25W	01121	CB3935
R235	315-0222-00			RES.,FXD,CMPSN:2.2K OHM,5%,0.25W	01121	CB2225
R236	315-0131-00			RES.,FXD,CMPSN:130 OHM,5%,0.25W	01121	CB1315

Replaceable Electrical Parts—214 Service

Ckt No.	Tektronix Part No.	Serial/Model No. Eff	Dscont	Name & Description	Mfr Code	Mfr Part Number
R238	315-0102-00			RES., FXD, CMPSN: 1K OHM, 5%, 0.25W	01121	CB1025
R239	315-0121-00	XB070000		RES., FXD, CMPSN: 120 OHM, 5%, 0.25W	01121	CB1215
R241	315-0131-00			RES., FXD, CMPSN: 130 OHM, 5%, 0.25W	01121	CB1315
R264	315-0104-00			RES., FXD, CMPSN: 100K OHM, 5%, 0.25W	01121	CB1045
R268	315-0274-00			RES., FXD, CMPSN: 270K OHM, 5%, 0.25W	01121	CB2745
R270	315-0333-00			RES., FXD, CMPSN: 33K OHM, 5%, 0.25W	01121	CB3335
R271	315-0274-00			RES., FXD, CMPSN: 270K OHM, 5%, 0.25W	01121	CB2745
R272	315-0105-00			RES., FXD, CMPSN: 1M OHM, 5%, 0.25W	01121	CB1055
R273	311-1252-00			RES., VAR, NONWIR: 500K OHM, 20%, 0.50W	32997	3386F-T04-504
R274	315-0514-00	XB010190	B039999	RES., FXD, CMPSN: 510K OHM, 5%, 0.25W	01121	CB5145
R274	315-0224-00			B040000	RES., FXD, CMPSN: 220K OHM, 5%, 0.25W	01121
R275	311-1274-00			RES., VAR, NONWIR: 500K OHM, 10%, 0.50W	32997	3329P-L58-504
R276	315-0334-00			RES., FXD, CMPSN: 330K OHM, 5%, 0.25W	01121	CB3345
R278	315-0100-00			RES., FXD, CMPSN: 10 OHM, 5%, 0.25W	01121	CB1005
R279	315-0100-00			RES., FXD, CMPSN: 10 OHM, 5%, 0.25W	01121	CB1005
R280	315-0681-00			RES., FXD, CMPSN: 680 OHM, 5%, 0.25W	01121	CB6815
R301	315-0105-00			RES., FXD, CMPSN: 1M OHM, 5%, 0.25W	01121	CB1055
R306A-F	307-0307-01			NTWK, HYB CKT: (FURNISHED AS A UNIT WITH C306B,D,F)	80009	307-0307-01
R311	315-0107-00			RES., FXD, CMPSN: 100M OHM, 5%, 0.25W	01121	CB1075
R312	315-0474-00			RES., FXD, CMPSN: 470K OHM, 5%, 0.25W	01121	CB4745
R313	315-0273-00			RES., FXD, CMPSN: 27K OHM, 5%, 0.25W	01121	CB2735
R314	321-0164-00	XB090000		RES., FXD, FILM: 499 OHM, 1%, 0.125W	91637	MFF1816G499ROF
R315	311-0634-00		B010100	B089999	RES., VAR, NONWIR: TRMR, 500 OHM, 0.5W	32997
R315	311-0622-00	B090000		RES., VAR, NONWIR: 100 OHM, 10%, 0.50W	32997	3326H-G48-101
R316	321-0318-02	B010100	B089999	RES., FXD, FILM: 20K OHM, 0.5%, 0.125W	91637	MFF1816D20001D
R316	321-0776-03	B090000		RES., FXD, FILM: 3.301K OHM, 0.25%, 0.125W	91637	MFF1816D35010C
R317	315-0271-00	B010100	B089999	RES., FXD, CMPSN: 270 OHM, 5%, 0.25W	01121	CB2715
R317	321-0168-00	B090000		RES., FXD, FILM: 549 OHM, 1%, 0.125W	91637	MFF1816G549ROF
R318	321-0318-02	B010100	B089999	RES., FXD, FILM: 20K OHM, 0.5%, 0.125W	91637	MFF1816D20001D
R318	321-0776-03	B090000		RES., FXD, FILM: 3.501K OHM, 0.25%, 0.125W	91637	MFF1816D35010C
R319A-E	307-0395-00			RES., FXD, FILM: 5 RES NETWORK	80009	307-0395-00
R320	311-1406-00			RES., VAR, NONWIR: 20K OHM, 0.25W, W/SW	71450	200-YA5557
R321	315-0103-00			RES., FXD, CMPSN: 10K OHM, 5%, 0.25W	01121	CB1035
R322	315-0512-00	XB090000		RES., FXD, CMPSN: 5.1K OHM, 5%, 0.25W	01121	CB5125
R323	321-0306-00			RES., FXD, FILM: 15K OHM, 1%, 0.125W	91637	MFF1816G15001F
R324	315-0271-00			RES., FXD, CMPSN: 270 OHM, 5%, 0.25W	01121	CB2715
R326	315-0473-00			RES., FXD, CMPSN: 47K OHM, 5%, 0.25W	01121	CB4735
R327	315-0822-00			RES., FXD, CMPSN: 8.2K OHM, 5%, 0.25W	01121	CB8225
R328	315-0162-00			RES., FXD, CMPSN: 1.6K OHM, 5%, 0.25W	01121	CB1625
R329	315-0183-00			RES., FXD, CMPSN: 18K OHM, 5%, 0.25W	01121	CB1835
R340	311-1422-00			RES., VAR, NONWIR: 20K OHM, 20%, 0.25W (FURNISHED AS A UNIT WITH S340)	71450	OBD
R341	315-0393-00			RES., FXD, CMPSN: 39K OHM, 5%, 0.25W	01121	CB3935
R342	321-0309-00			RES., FXD, FILM: 16.2K OHM, 1%, 0.125W	91637	MFF1816G16201F
R343	321-0251-00			RES., FXD, FILM: 4.02K OHM, 1%, 0.125W	91637	MFF1816G40200F
R344	315-0682-00			RES., FXD, CMPSN: 6.8K OHM, 5%, 0.25W	01121	CB6825
R346	315-0104-00			RES., FXD, CMPSN: 100K OHM, 5%, 0.25W	01121	CB1045
R348	315-0114-00			RES., FXD, CMPSN: 110K OHM, 5%, 0.25W	01121	CB1145
R349	315-0914-00			RES., FXD, CMPSN: 910K OHM, 5%, 0.25W	01121	CB9145
R351	315-0912-00			RES., FXD, CMPSN: 9.1K OHM, 5%, 0.25W	01121	CB9125
R352	315-0222-00			RES., FXD, CMPSN: 2.2K OHM, 5%, 0.25W	01121	CB2225
R355	315-0273-00			RES., FXD, CMPSN: 27K OHM, 5%, 0.25W	01121	CB2735
R361A-F	307-0308-00			RES., FXD, FILM: TIMING, HYBRID CKT	80009	307-0308-00
R362	325-0118-00			RES., FXD, FILM: 3M OHM, 1%, 0.125W	03888	PME55-G30003F
R364	315-0104-00			RES., FXD, CMPSN: 100K OHM, 5%, 0.25W	01121	CB1045
R365	315-0204-00			RES., FXD, CMPSN: 200K OHM, 5%, 0.25W	01121	CB2045

Ckt No.	Tektronix Part No.	Serial/Model No. Eff	Dscont	Name & Description	Mfr Code	Mfr Part Number
R366	311-1243-00			RES., VAR, NONWIR: 500K OHM, 10%, 0.50W	73138	72-34-0
R368	315-0223-00			RES., FXD, CMPSN: 22K OHM, 5%, 0.25W	01121	CB2235
R369	315-0273-00			RES., FXD, CMPSN: 27K OHM, 5%, 0.25W	01121	CB2735
R370	311-1272-00			RES., VAR, NONWIR: 100K OHM, 10%, 0.50W	32997	3329P-L58-104
R371	317-0391-00	XB080000		RES., FXD, CMPSN: 390 OHM, 5%, 0.125W	01121	BB3915
R372	315-0105-00			RES., FXD, CMPSN: 1M OHM, 5%, 0.25W	01121	CB1055
R374	311-1269-00			RES., VAR, NONWIR: 20K OHM, 10%, 0.50W	32997	3329P-L58-203
R375	311-1173-00			RES., VAR, NONWIR: 20K OHM, 20%, 0.25W (FURNISHED AS A UNIT WITH S375)	71450	200-YA5541
R376	315-0103-00			RES., FXD, CMPSN: 10K OHM, 5%, 0.25W	01121	CB1035
R380	315-0102-00			RES., FXD, CMPSN: 1K OHM, 5%, 0.25W	01121	CB1025
R381	315-0183-00			RES., FXD, CMPSN: 18K OHM, 5%, 0.25W	01121	CB1835
R383	315-0122-00			RES., FXD, CMPSN: 1.2K OHM, 5%, 0.25W	01121	CB1225
R385	315-0224-00			RES., FXD, CMPSN: 220K OHM, 5%, 0.25W	01121	CB2245
R388	315-0271-00	B010100 B109194	B109194	RES., FXD, CMPSN: 270 OHM, 5%, 0.25W	01121	CB2715
R388	315-0301-00			B109195		RES., FXD, CMPSN: 300 OHM, 5%, 0.25W
R390	315-0682-00			RES., FXD, CMPSN: 6.8K OHM, 5%, 0.25W	01121	CB6825
R391	315-0102-00			RES., FXD, CMPSN: 1K OHM, 5%, 0.25W	01121	CB1025
R393	315-0104-00			RES., FXD, CMPSN: 100K OHM, 5%, 0.25W	01121	CB1045
R394	311-1275-00			RES., VAR, NONWIR: 1M OHM, 10%, 0.50W	32997	3329P-L58-105
R395	311-1169-00			RES., VAR, NONWIR: PNL, 2M OHM, 0.2W	71450	OBD
R396	316-0225-00			RES., FXD, CMPSN: 2.2M OHM, 10%, 0.25W	01121	CB2251
R401	315-0105-00			RES., FXD, CMPSN: 1M OHM, 5%, 0.25W	01121	CB1055
R406A-F	307-0307-01			NTWK, HYB CKT: (FURNISHED AS A UNIT WITH C406B, D, F)	80009	307-0307-01
R411	315-0107-00			RES., FXD, CMPSN: 100M OHM, 5%, 0.25W	01121	CB1075
R412	315-0474-00			RES., FXD, CMPSN: 470K OHM, 5%, 0.25W	01121	CB4745
R413	315-0273-00			RES., FXD, CMPSN: 27K OHM, 5%, 0.25W	01121	CB2735
R414	321-0164-00	XB090000		RES., FXD, FILM: 499 OHM, 1%, 0.125W	91637	MFF1816G499ROF
R415	315-0271-00		B010100	B089999	RES., FXD, CMPSN: 270 OHM, 5%, 0.25W	01121
R415	321-0168-00	B090000		RES., FXD, FILM: 549 OHM, 1%, 0.125W	91637	MFF1816G549ROF
R416	321-0318-02	B010100	B089999	RES., FXD, FILM: 20K OHM, 0.5%, 0.125W	91637	MFF1816D20001D
R416	321-0776-03	B090000		RES., FXD, FILM: 3.501K OHM, 0.25%, 0.125W	91637	MFF1816D35010C
R417	311-0634-00	B010100	B089999	RES., VAR, NONWIR: TRMR, 500 OHM, 0.5W	32997	3326H-G48-501
R417	311-0622-00	B090000		RES., VAR, NONWIR: 100 OHM, 10%, 0.50W	32997	3329H-G48-101
R418	321-0318-02	B010100	B089999	RES., FXD, FILM: 20K OHM, 0.5%, 0.125W	91637	MFF1816D20001D
R418	321-0776-03	B090000		RES., FXD, FILM: 3.501K OHM, 0.25%, 0.125W	91637	MFF1816D35010C
R419A-E	307-0395-00			RES., FXD, FILM: 5 RES NETWORK	80009	307-0395-00
R420	311-1406-00			RES., VAR, NONWIR: 20K OHM, 0.25W, W/SW	71450	200-YA5557
R421	315-0103-00			RES., FXD, CMPSN: 10K OHM, 5%, 0.25W	01121	CB1035
R422	315-0512-00	XB090000		RES., FXD, CMPSN: 5.1K OHM, 5%, 0.25W	01121	CB5125
R423	321-0306-00				RES., FXD, FILM: 15K OHM, 1%, 0.125W	91637
R424	315-0561-00			RES., FXD, CMPSN: 560 OHM, 5%, 0.25W	01121	CB5615
R425	315-0243-00			RES., FXD, CMPSN: 24K OHM, 5%, 0.25W	01121	CB2435
R440	311-1422-00			RES., VAR, NONWIR: 20K OHM, 20%, 0.25W (FURNISHED AS A UNIT WITH S440)	71450	OBD
R441	315-0393-00			RES., FXD, CMPSN: 39K OHM, 5%, 0.25W	01121	CB3935
R442	321-0309-00			RES., FXD, FILM: 16.2K OHM, 1%, 0.125W	91637	MFF1816G16201F
R443	321-0251-00			RES., FXD, FILM: 4.02K OHM, 1%, 0.125W	91637	MFF1816G40200F
R446	315-0104-00			RES., FXD, CMPSN: 100K OHM, 5%, 0.25W	01121	CB1045
R451	315-0912-00			RES., FXD, CMPSN: 9.1K OHM, 5%, 0.25W	01121	CB9125
R452	315-0222-00			RES., FXD, CMPSN: 2.2K OHM, 5%, 0.25W	01121	CB2225
R454	315-0102-00			RES., FXD, CMPSN: 1K OHM, 5%, 0.25W	01121	CB1025
R470	311-1269-00			RES., VAR, NONWIR: 20K OHM, 10%, 0.50W	32997	3329P-L58-203
R471	315-0223-00			RES., FXD, CMPSN: 22K OHM, 5%, 0.25W	01121	CB2235
R472	315-0223-00			RES., FXD, CMPSN: 22K OHM, 5%, 0.25W	01121	CB2235
R473	315-0472-00			RES., FXD, CMPSN: 4.7K OHM, 5%, 0.25W	01121	CB4725
R474	315-0103-00			RES., FXD, CMPSN: 10K OHM, 5%, 0.25W	01121	CB1035

Replaceable Electrical Parts—214 Service

Ckt No.	Tektronix Part No.	Serial/Model No. Eff	Dscont	Name & Description	Mfr Code	Mfr Part Number
R475	311-1269-00			RES., VAR, NONWIR: 20K OHM, 10%, 0.50W	32997	3329P-L58-203
R476	311-1172-00			RES., VAR, NONWIR: PNL, 50K OHM, 0.2W, W/SW (FURNISHED AS A UNIT WITH S476)	71450	200-YA5540
R477	315-0333-00			RES., FXD, CMPSN: 33K OHM, 5%, 0.25W	01121	CB3335
R480	311-1171-00			RES., VAR, NONWIR: PNL, 100K OHM, 0.25W	71450	FX9406
R481	315-0333-00			RES., FXD, CMPSN: 33K OHM, 5%, 0.25W	01121	CB3335
R482	315-0683-00			RES., FXD, CMPSN: 68K OHM, 5%, 0.25W	01121	CB6835
R485	315-0224-00			RES., FXD, CMPSN: 220K OHM, 5%, 0.25W	01121	CB2245
R491	315-0150-00			RES., FXD, CMPSN: 15 OHM, 5%, 0.25W	01121	CB1505
R493	315-0150-00			RES., FXD, CMPSN: 15 OHM, 5%, 0.25W	01121	CB1505
R501	321-0407-00			RES., FXD, FILM: 169K OHM, 1%, 0.125W	91637	MFF1816G16902F
R502	321-0423-00			RES., FXD, FILM: 249K OHM, 1%, 0.125W	91637	MFF1816G24902F
R505	315-0105-00			RES., FXD, CMPSN: 1M OHM, 5%, 0.25W	01121	CB1055
R506	311-1275-00			RES., VAR, NONWIR: 1M OHM, 10%, 0.50W	32997	3329P-L58-105
R508	315-0474-00			RES., FXD, CMPSN: 470K OHM, 5%, 0.25W	01121	CB4745
R510	311-1275-00			RES., VAR, NONWIR: 1M OHM, 10%, 0.50W	32997	3329P-L58-105
R511	315-0474-00			RES., FXD, CMPSN: 470K OHM, 5%, 0.25W	01121	CB4745
R512	315-0684-00			RES., FXD, CMPSN: 680K OHM, 5%, 0.25W	01121	CB6845
R513	315-0221-00	B010100	B010331	RES., FXD, CMPSN: 220 OHM, 5%, 0.25W	01121	CB2215
R513	315-0121-00	B010332		RES., FXD, CMPSN: 120 OHM, 5%, 0.25W	01121	CB1215
R515	311-1274-00			RES., VAR, NONWIR: 500K OHM, 10%, 0.50W	32997	3329P-L58-504
R516	315-0274-00			RES., FXD, CMPSN: 270K OHM, 5%, 0.25W	01121	CB2745
R521	315-0333-00			RES., FXD, CMPSN: 33K OHM, 5%, 0.25W	01121	CB3335
R522	316-0225-00	B010100	B049999	RES., FXD, CMPSN: 2.2M OHM, 10%, 0.25W	01121	CB2251
R522	315-0475-00	B050000		RES., FXD, CMPSN: 4.7K OHM, 5%, 0.25W	01121	CB4755
R523	315-0472-00			RES., FXD, CMPSN: 4.7K OHM, 5%, 0.25W	01121	CB4725
R524	315-0153-00	XB050000		RES., FXD, CMPSN: 15K OHM, 5%, 0.25W	01121	CB1535
R525	311-1272-00			RES., VAR, NONWIR: 100K OHM, 10%, 0.50W	32997	3329P-L58-104
R526	315-0104-00	B010100	B049999X	RES., FXD, CMPSN: 100K OHM, 5%, 0.25W	01121	CB1045
R527	315-0153-00	B010100	B049999	RES., FXD, CMPSN: 15K OHM, 5%, 0.25W	01121	CB1535
R527	315-0203-00	B050000		RES., FXD, CMPSN: 20K OHM, 5%, 0.25W	01121	CB2035
R529	315-0101-00	XB010332		RES., FXD, CMPSN: 100 OHM, 5%, 0.25W	01121	CB1015
R530	315-0473-00	B010100	B108947	RES., FXD, CMPSN: 47K OHM, 5%, 0.25W	01121	CB4735
R530	315-0562-00	B108948		RES., FXD, CMPSN: 5.6K OHM, 5%, 0.25W	01121	CB5625
R531	315-0113-00			RES., FXD, CMPSN: 11K OHM, 5%, 0.25W	01121	CB1135
R532	315-0152-00			RES., FXD, CMPSN: 1.5K OHM, 5%, 0.25W	01121	CB1525
R535	315-0152-00			RES., FXD, CMPSN: 1.5K OHM, 5%, 0.25W	01121	CB1525
R536	315-0472-00			RES., FXD, CMPSN: 4.7K OHM, 5%, 0.25W	01121	CB4725
R537	315-0473-00			RES., FXD, CMPSN: 47K OHM, 5%, 0.25W	01121	CB4735
R541	315-0153-00			RES., FXD, CMPSN: 15K OHM, 5%, 0.25W	01121	CB1535
S215	260-0723-00			SWITCH, SLIDE: DPDT, 0.5A, 125VAC	79727	GF126-0028
S305	260-0984-00	B010100	B052399	SWITCH, SLIDE: DP3T, 0.5A, 125V	79727	G-128-S-0012
S305	260-0984-01	B052400		SWITCH, SLIDE: DP3T W/PLASTIC PLATE	79727	G-128SPC/
S310	214-1577-01			DTT-CONT ASSY: 2 CONTACT	80009	214-1577-01
S340	-----			(FURNISHED AS A UNIT WITH R340)		
S345	260-0984-00	B010100	B052399	SWITCH, SLIDE: DP3T, 0.5A, 125V	79727	G-128-S-0012
S345	260-0984-01	B052400		SWITCH, SLIDE: DP3T W/PLASTIC PLATE	79727	G-128SPC/
S360	214-1576-01			DTT-CONT ASSY: 3 CONTACT	80009	214-1576-01
S375	-----			(FURNISHED AS A UNIT WITH R375)		
S405	260-0984-00	B010100	B052399	SWITCH, SLIDE: DP3T, 0.5A, 125V	79727	G-128-S-0012
S405	260-0984-01	B052400		SWITCH, SLIDE: DP3T W/PLASTIC PLATE	79727	G-128SPC/
S410	214-1577-01			DTT-CONT ASSY: 2 CONTACT	80009	214-1577-01
S440	-----			(FURNISHED AS A UNIT WITH R440)		
S476	-----			(FURNISHED AS A UNIT WITH R476)		
S510A	670-2676-00	B010100	B059999	CKT BOARD ASSY: SINGLE SWEEP (SEE MPL FOR REPLACEMENT PARTS)	80009	670-2676-00
S510B						
S510C						
S510D						

Ckt No.	Tektronix Part No.	Serial/Model No. Eff	Dscont	Name & Description	Mfr Code	Mfr Part Number
S510A) S510B) S510C) S510D)	670-2676-01 -----	B060000		CKT BOARD ASSY:SINGLE SWEEP (SEE MPL FOR REPLACEMENT PARTS)	80009	670-2676-01
T207	120-0864-00	B010100	B053086	TRANSFORMER,CMR:	80009	120-0864-00
T207	120-1043-00	B053087	B054659	TRANSFORMER,RF:COMMON MODE REJ,POT CORE	80009	120-1043-00
T207	120-1103-00	B054660		XFMR,RF:POT CORE	80009	120-1103-00
T250	120-0735-00			XFMR,PWR,SDN&SU:	80009	120-0735-00
T270	108-0772-00			COIL,RF:FIXED,148UH	80009	108-0772-00
T280	120-0865-00	B010100	B050969	XFMR,PWR,SDN&SU:	80009	120-0865-00
T280	120-0865-01	B050970		XFMR,RF:	80009	120-0865-01
U105	155-0047-00			MICROCIRCUIT,LI:OUTPUT AMPLIFIER	80009	155-0047-00
U320	155-0083-00			MICROCIRCUIT,LI:DUAL OPNL AMPL & CHAN SW	80009	155-0083-00
U370	155-0048-00			MICROCIRCUIT,DI:TRIG & SWEEP AMPL	80009	155-0048-00
U440	156-0280-00			MICROCIRCUIT,DI:J-K MASTER-SLAVE FLIP-FLOP	80009	156-0280-00
V300	154-0695-00 -----	B010100	B049999	ELECTRON TUBE:CRT,P400,INT SCALE (FURNISHED AS A UNIT WITH L300)	80009	154-0695-00
V300	154-0732-00 -----	B050000		ELECTRON TUBE:CRT,P400,INT SCALE (FURNISHED AS A UNIT WITH L300)	80009	154-0732-00
VR228	152-0306-00			SEMICONV DEVICE:ZENER,0.4W,9.1V,5%	14433	1N960B
VR238	152-0514-00			SEMICONV DEVICE:ZENER,0.4W,10V,1%	80009	152-0514-00

<http://www.ebaman.com>

OPTION INFORMATION

Your instrument may be equipped with one or more options. This section describes those options or directs the reader to where the option is documented.

OPTION 1

Option 1 equips the 214 for operation from a 220 to 250 V ac 48 to 52 Hz power line source. Option 1 parts values that differ from the standard 214 are listed here. A power cord cable assembly for adapting to appropriate power plugs, is included with Option 1 instruments. Refer to the Maintenance and Diagrams section of this manual for additional information concerning Option 1.

ELECTRICAL PARTS LIST DIFFERENCES FOR OPTION 1

A3	670-2741-21*	POWER SUPPLY Circuit Board Assembly (Option 1)
C204	283-0279-00	0.001 UF, 20%, 3 KV
C210	285-0933-00	2.0 UF, 10%, 400 V
C212	285-0933-00	2.0 UF, 10%, 400 V
C215	283-0279-00	0.001 UF, 20%, 3 KV

ADDITIONAL STANDARD ACCESSORIES FOR OPTION 1

161-0077-01	CABLE ASSEMBLY, POWER (Adapts to users plug type)
-------------	--

*In some Option 1 instruments, the suffix number on the board may not be marked —21.

OPTION 2

Option 2 equips the 214 for operation from a 90 to 110 V ac 48 to 52 Hz power line source. Option 2 parts values that differ from the standard 214 are listed here. Refer to the Maintenance and Diagrams sections of the manual for additional information concerning Option 2.

ELECTRICAL PARTS LIST DIFFERENCES FOR OPTION 2

A3	670-2741-31**	POWER SUPPLY Circuit Board Assembly (Option 2)
C210	285-0935-00	4.4 UF, 10%, 200 V
C212	285-0935-00	4.4 UF, 10%, 200 V

**In some Option 2 instruments, the suffix number on the board may not be marked —31.

REPLACEABLE MECHANICAL PARTS

PARTS ORDERING INFORMATION

Replacement parts are available from or through your local Tektronix, Inc. Field Office or representative.

Changes to Tektronix instruments are sometimes made to accommodate improved components as they become available, and to give you the benefit of the latest circuit improvements developed in our engineering department. It is therefore important, when ordering parts, to include the following information in your order: Part number, instrument type or number, serial number, and modification number if applicable.

If a part you have ordered has been replaced with a new or improved part, your local Tektronix, Inc. Field Office or representative will contact you concerning any change in part number.

Change information, if any, is located at the rear of this manual.

SPECIAL NOTES AND SYMBOLS

X000 Part first added at this serial number
00X Part removed after this serial number

FIGURE AND INDEX NUMBERS

Items in this section are referenced by figure and index numbers to the illustrations.

INDENTATION SYSTEM

This mechanical parts list is indented to indicate item relationships. Following is an example of the indentation system used in the description column.

```

1 2 3 4 5           Name & Description
Assembly and/or Component
Attaching parts for Assembly and/or Component
    --- * ---
Detail Part of Assembly and/or Component
Attaching parts for Detail Part
    --- * ---
Parts of Detail Part
Attaching parts for Parts of Detail Part
    --- * ---
  
```

Attaching Parts always appear in the same indentation as the item it mounts, while the detail parts are indented to the right. Indented items are part of, and included with, the next higher indentation. The separation symbol --- * --- indicates the end of attaching parts.

Attaching parts must be purchased separately, unless otherwise specified.

ITEM NAME

In the Parts List, an Item Name is separated from the description by a colon (:). Because of space limitations, an Item Name may sometimes appear as incomplete. For further Item Name identification, the U.S. Federal Cataloging Handbook H6-1 can be utilized where possible.

ABBREVIATIONS

"	INCH	ELCTRN	ELECTRON	IN	INCH	SE	SINGLE END
#	NUMBER SIZE	ELEC	ELECTRICAL	INCAND	INCANDESCENT	SECT	SECTION
ACTR	ACTUATOR	ELECTLT	ELECTROLYTIC	INSUL	INSULATOR	SEMICON	SEMICONDUCTOR
ADPTR	ADAPTER	ELEM	ELEMENT	INTL	INTERNAL	SHLD	SHIELD
ALIGN	ALIGNMENT	EPL	ELECTRICAL PARTS LIST	LPHLDR	LAMPHOLDER	SHLDR	SHOULDERED
AL	ALUMINUM	EQPT	EQUIPMENT	MACH	MACHINE	SKT	SOCKET
ASSEM	ASSEMBLED	EXT	EXTERNAL	MECH	MECHANICAL	SL	SLIDE
ASSY	ASSEMBLY	FIL	FILLISTER HEAD	MTG	MOUNTING	SLFLKG	SELF-LOCKING
ATTEN	ATTENUATOR	FLEX	FLEXIBLE	NIP	NIPPLE	SLVG	SLEEVEING
AWG	AMERICAN WIRE GAGE	FLH	FLAT HEAD	NON WIRE	NOT WIRE WOUND	SPR	SPRING
BD	BOARD	FLTR	FILTER	OB	ORDER BY DESCRIPTION	SO	SQUARE
BRKT	BRACKET	FR	FRAME or FRONT	OD	OUTSIDE DIAMETER	SST	STAINLESS STEEL
BRS	BRASS	FSTNR	FASTENER	OVH	OVAL HEAD	STL	STEEL
BRZ	BRONZE	FT	FOOT	PH BRZ	PHOSPHOR BRONZE	SW	SWITCH
BSHG	BUSHING	FXD	FIXED	PL	PLAIN or PLATE	T	TUBE
CAB	CABINET	GSKT	GASKET	PLSTC	PLASTIC	TERM	TERMINAL
CAP	CAPACITOR	HDL	HANDLE	PN	PART NUMBER	THD	THREAD
CER	CERAMIC	HEX	HEXAGON	PNH	PAN HEAD	THK	THICK
CHAS	CHASSIS	HEX HD	HEXAGONAL HEAD	PWR	POWER	TNSN	TENSION
CKT	CIRCUIT	HEX SOC	HEXAGONAL SOCKET	RCPT	RECEPTACLE	TPG	TAPPING
COMP	COMPOSITION	HLCPS	HELICAL COMPRESSION	RES	RESISTOR	TRH	TRUSS HEAD
CONN	CONNECTOR	HLEXT	HELICAL EXTENSION	RGD	RIGID	V	VOLTAGE
COV	COVER	HV	HIGH VOLTAGE	RLF	RELIEF	VAR	VARIABLE
CPLG	COUPLING	IC	INTEGRATED CIRCUIT	RTNR	RETAINER	W/	WITH
CRT	CATHODE RAY TUBE	ID	INSIDE DIAMETER	SCH	SOCKET HEAD	WSHR	WASHER
DEG	DEGREE	IDNT	IDENTIFICATION	SCOPE	OSCILLOSCOPE	XFMR	TRANSFORMER
DWR	DRAWER	IMPLR	IMPELLER	SCR	SCREW	XSTR	TRANSISTOR

CROSS INDEX—MFR. CODE NUMBER TO MANUFACTURER

Mfr. Code	Manufacturer	Address	City, State, Zip
00779	AMP, INC.	P O BOX 3608	HARRISBURG, PA 17105
08530	RELIANCE MICA CORP.	342-39TH ST.	BROOKLYN, NY 11232
16428	BELDEN CORP.	P. O. BOX 1331	RICHMOND, IN 47374
17516	MOORE, MAYNARD H., JR., INC.	430 MAIN ST.	STONEHAM, MA 02180
18121	WILSHIRE FOAM PRODUCTS, INC.	2665 COLUMBIA ST.	TORRANCE, CA 90503
19209	GENERAL ELECTRIC CO., ELECTRONIC CAPACITOR AND BATTERY PRODUCTS DEPT. BATTERY PRODUCTS SEC.	P. O. BOX 114	GAINESVILLE, FL 32601
22526	BERG ELECTRONICS, INC.	YOUK EXPRESSWAY	NEW CUMBERLAND, PA 17070
23050	PRODUCT COMPONENTS CORP	30 LORRAINE AVE.	MT VERNON, NY 10553
71785	TRW, CINCH CONNECTORS	1501 MORSE AVENUE	ELK GROVE VILLAGE, IL 60007
73743	FISCHER SPECIAL MFG. CO.	446 MORGAN ST.	CINCINNATI, OH 45206
73803	TEXAS INSTRUMENTS, INC., METALLURGICAL MATERIALS DIV.	34 FOREST STREET	ATTLEBORO, MA 02703
76545	MUELLER ELECTRIC CO.	1583 EAST 31ST ST.	CLEVELAND, OH 44114
78189	ILLINOIS TOOL WORKS, INC. SHAKEPROOF DIVISION	ST. CHARLES ROAD	ELGIN, IL 60120
79727	C-W INDUSTRIES	550 DAVISVILLE RD., P O BOX 96	WARMINISTER, PA 18974
80009	TEKTRONIX, INC.	P O BOX 500	BEAVERTON, OR 97077
80710	ALLEGHENY LUDLUM STEEL CORP., A DIVISION OF ALLEGHENY LUDLUM INDUSTRIES, INC.	BRACKENRIDGE WORKS, RIVER AVE.	BRACKENRIDGE, PA 15014
83385	CENTRAL SCREW CO.	2530 CRESCENT DR.	BROADVIEW, IL 60153
98278	MALCO A MICRODOT COMPANY, INC. CONNECTOR AND CABLE DIVISION	220 PASADENA AVE.	SOUTH PASADENA, CA 91030

<http://www.ebaman.com>

Fig. & Index No.	Tektronix Part No.	Serial/Model No. Eff Dscont	Qty	1 2 3 4 5	Name & Description	Mfr Code	Mfr Part Number
1-1	366-1468-01		1		KNOB:DARK GRAY	80009	366-1468-01
-2	366-1469-01		1		KNOB:LIGHT GRAY	80009	366-1469-01
-3	366-1322-05		1		KNOB:DARK GRAY--POS	80009	366-1322-05
-4	366-1466-02		1		KNOB:LT GRAY--POS	80009	366-1466-02
-5	366-1322-02		1		KNOB:DARK GRAY--VAR	80009	366-1322-02
-6	366-1466-01		1		KNOB:LT GRAY--VAR	80009	366-1466-01
-7	366-1467-03		1		KNOB:DARK GRAY--TRG	80009	366-1467-03
-8	366-1467-02		1		KNOB:DARK GRAY--INT	80009	366-1467-02
-9	366-1467-01		1		KNOB:DARK GRAY--VAR	80009	366-1467-01
-10	366-1467-04		1		KNOB:DARK GRAY--POS	80009	366-1467-04
-11	366-1470-01		1		KNOB:MEDIUM GRAY	80009	366-1470-01
-12	348-0285-00		1		FLIP-STAND,CAB:1.94 H X 3.424 INCH WIDE (ATTACHING PARTS)	80009	348-0285-00
-13	211-0213-00		1		SCREW,MACHINE:4-40 X 0.312 INCH,PNH NYLON	23050	OBD
-14	211-0170-00		2		SCREW,MACHINE:4-40 X 2.75 INCH,PNH STL	83385	OBD
-15	355-0181-00		2		STUD,CRYG,HDL:0.312 DIA X 0.50 INCH LONG	80009	355-0181-00
-16	211-0019-00		2		SCREW,MACHINE:4-40 X 1.0 INCH,PNH STL	83385	OBD
					- - - * - - -		
-17	437-0147-01		1		CABINET,SCOPE:	80009	437-0147-01
-18	214-1850-00		4		. PIN,ALIGNMENT:CIRCUIT BOARD	80009	214-1850-00
-19	348-0254-01		4		. FOOT,CABINET:BLACK RUBBER	80009	348-0254-01
-20	334-1859-00		1		MARKER,IDENT:STANDARD	80009	334-1859-00
-21	386-1999-00		1		SUPPORT,CRT:FRONT	80009	386-1999-00
	331-0445-00	XB055100	1		MASK,CRT SCALE:	80009	331-0445-00
-22	378-0691-00		1		FILTER,LT,CRT:BLUE	80009	378-0691-00
-23	354-0423-00		1		RING,SPRT,CRT:RUBBER	80009	354-0423-00
-24	253-0153-00		FT		TAPE,PRESS.SENS:0.25 W X 0.125"THK FOAM	18121	P7/PVC
-25	337-1458-00		1		SHLD,ELECTRON T:CATHODE RAY TUBE	80710	337-1458-00-D
-26	386-2185-00		1		SPRT,CRT SHIELD:REAR	80009	386-2185-00
-27	200-1400-00		1		COVER,PLUG:POWER CORD	80009	200-1400-00
-28	214-1805-00		1		SPOOL,CORD WRAP:	80009	214-1805-00
-29	200-1469-00		2		COVER,CORD WRAP:UPPER & LOWER	80009	200-1469-00
-30	200-1470-00		1		COVER,CORD WRAP:PROBE,UPPER	80009	200-1470-00
-31	200-1467-00		1		COVER,CORD WRAP:PROBE,LOWER	80009	200-1467-00
-32	-----		1		CKT BOARD ASSY:AMPLIFIER(SEE A2 EPL)		
	-----		-		. CKT BOARD ASSY INCLUDES:		
-33	131-0608-00		9		. TERMINAL,PIN:0.365 L X 0.25 PH,BRZ,GOLD PL	22526	47357
-34	131-1172-00		1		. CONTACT,ELEC:CKT CARD GROUND	80009	131-1172-00
-35	136-0252-04		31		. SOCKET,PIN TERM:U/W 0.016-0.018 DIA PINS	22526	75060-007
-36	136-0328-03		12		. SOCKET,PIN TERM:HORIZ,SQ PIN RCPT	22526	47710
	136-0549-00		1		. SKT,PL-IN ELEK:ELCTR N TUBE,11CONT W/LEADS	80009	136-0549-00
-37	136-0453-00		1		. . SOCKET,PLUG-IN:11 PIN,CRT	80009	136-0453-00
-38	352-0169-00		1		. . HLDR,TERM CONN:2 WIRE BLACK	80009	352-0169-00
-39	352-0199-00		1		. . CONN BODY,PL,EL:3 WIRE BLACK	80009	352-0199-00
-40	131-0707-00	B010100 B054556	2		. . CONNECTOR,TERM.:22-26 AWG,BRS& CU BE GOLD	22526	47439
	131-0707-00	B054557	7		. . CONNECTOR,TERM.:22-26 AWG,BRS& CU BE GOLD	22526	47439
-41	131-0621-00		3		. . CONNECTOR,TERM:22-26 AWG,BRS& CU BE GOLD	22526	46231
	131-0371-00	B010100 B054556X	7		. . CONTACT,ELEC:FOR NO.26 AWG WIRE	98278	122-0182-019
	131-1109-00	B010100 B040499	11		. . CONNECTOR,PLUG:CRIMP ON,FOR 0.4" OD PIN	00779	42869-6
	131-1109-00	B040500	7		. . CONNECTOR,PLUG:CRIMP ON,FOR 0.4" OD PIN	00779	42869-6
	131-1109-02	XB040500	4		. . CONNECTOR,TERM:CRIMP ON,FOR 0.4" OD PIN	00779	P73-7444
-42	253-0154-00		4		. TAPE,PRESS.SENS:0.125"THK	18121	MT8
-43	342-0113-00		1		. INSULATOR,PLATE:CKT CARD,FILM	80009	342-0113-00
	-----		2		BATTERY ASSY:(SEE BT216/BT217 EPL)		
	-----		-		. EACH BATTERY ASSY INCLUDES:		
-44	200-1238-01		2		. COVER,BAT SET:PLASTIC,BLACK	80009	200-1238-01
-45	146-0026-00		1		. BATTERY SET:6V,660 MAH,5A CELL	19209	41B906FD02-G1
	198-3183-00		1		. WIRE SET,ELEC:	80009	198-3183-00
-46	352-0161-00		1		. . HLDR,TERM CONN:3 WIRE BLACK	80009	352-0161-00
-47	131-0707-00		3		. . CONNECTOR,TERM.:22-26 AWG,BRS& CU BE GOLD	22526	47439
	253-0153-00		FT		. TAPE,PRESS.SENS:0.25 W X 0.125"THK FOAM	18121	P7/PVC
-48	-----		1		CKT BOARD ASSY:POWER SUPPLY(SEE A3 EPL)		
-49	131-0589-00		47		. TERM,PIN:0.46 L X 0.025 SQ.PH BRZ GL	22526	47350
-50	136-0252-04		24		. SOCKET,PIN TERM:U/W 0.016-0.018 DIA PINS	22526	75060-007

Replaceable Mechanical Parts—214 Service

Fig. & Index No.	Tektronix Part No.	Serial/Model No. Eff Dscont	Qty	1 2 3 4 5	Name & Description	Mfr Code	Mfr Part Number
1-51	348-0089-00		1	.	BUMPER, PLASTIC: BLACK VINYL	80009	348-0089-00
-52	253-0154-00		4	.	TAPE, PRESS. SENS: 0.125" THK	18121	MT8
-53	342-0176-00		1	.	INSULATOR, FILM: CIRCUIT CARD	80009	342-0176-00
-54	131-1172-00		1	.	CONTACT, ELEC: CKT CARD GROUND	80009	131-1172-00
-55	334-1926-00		2	.	MARKER, IDENT: DANGER	80009	334-1926-00
-56	344-0255-00		2	.	CLIP, ELECTRICAL: FUSE MOUNT	80009	344-0255-00
-57	161-0078-00		1	.	CABLE ASSY, PWR, : 2 WIRE, 48 INCH LONG	16428	KG12127
-58	166-0548-00		1	.	FERRULE, RF CA: 0.144 ID X 0.227 OD, GND	80009	166-0548-00
-59	384-1198-00		4	.	EXTENSION SHAFT: STORAGE SWITCH	80009	384-1198-00
-60	-----		1	.	CKT BOARD ASSY: SINGLE SWEEP (SEE A4 EPL) (ATTACHING PARTS)		
-61	211-0125-00		2	.	SCREW, MACHINE: 1-72 X 0.25 INCH, PNH STL -----*-----	83385	OBD
-62	366-1493-00		1	.	ACTR ASSY, PB: 4 BUTTON, 0.3 SPACING	80009	366-1493-00
-63	131-0589-00		2	.	TERM, PIN: 0.46 L X 0.025 SQ. PH BRZ GL	22526	47350
-64	136-0252-04		12	.	SOCKET, PIN TERM: U/W 0.016-0.018 DIA PINS	22526	75060-007
-65	131-0608-00		3	.	TERMINAL, PIN: 0.365 L X 0.25 PH, BRZ, GOLD PL	22526	47357
-66	136-0328-02		11	.	SOCKET, PIN TERM: HORIZONTAL	00779	86282-2
-67	131-0722-00		6	.	CONTACT, ELEC: CAM SW, CU BE	80009	131-0722-00
-68	342-0095-00		1	.	INSULATOR, FILM: SHIELD, POLYESTER	80009	342-0095-00
-69	337-1795-00		1	.	SHIELD, ELEC: STORAGE SWITCH (ATTACHING PARTS)	80009	337-1795-00
-70	211-0062-00		1	.	SCREW, MACHINE: 2-56 X 0.312 INCH, RDH STL	83385	OBD
-71	361-0549-00		1	.	SPACER, SLEEVE: 0.105 L X 0.093 ID, AL	80009	361-0549-00
-72	210-0001-00		1	.	WASHER, LOCK: INTL, 0.092 ID X 0.18" OD, STL	78189	1202-00-00-0541C
-73	210-0405-00		1	.	NUT, PLAIN, HEX.: 2-56 X 0.188 INCH, BRS -----*-----	73743	2X12157-402
-74	407-1285-00		1	.	BRACKET, ELEC SW: ALUMINUM (ATTACHING PARTS)	80009	407-1285-00
-75	211-0019-00		1	.	SCREW, MACHINE: 4-40 X 1.0 INCH, PNH STL -----*-----	83385	OBD
-76	-----		1	.	CKT BOARD ASSY: INPUT (SEE A1 EPL) (ATTACHING PARTS)		
-77	211-0008-00		3	.	SCREW, MACHINE: 4-40 X 0.25 INCH, PNH STL -----*-----	83385	OBD
-78	136-0252-04		60	.	SOCKET, PIN TERM: U/W 0.016-0.018 DIA PINS	22526	75060-007
-79	136-0269-02		1	.	SKT, PL-IN ELEK: MICRO CIRCUIT, 14 DIP, LOW CLE	73803	CS9002-14
-80	131-0787-00		12	.	CONTACT, ELEC: 0.64 INCH LONG	22526	47359
-81	337-1734-00		1	.	SHIELD, ELEC: ATTENUATOR, REAR	80009	337-1734-00
-82	337-1735-00		1	.	SHIELD, ELEC: ATTENUATOR, FRONT (ATTACHING PARTS)	80009	337-1735-00
-83	211-0091-00		1	.	SCREW, MACHINE: 2-56 X 0.875, OVH, SST	83385	OBD
-84	210-0001-00		1	.	WASHER, LOCK: INTL, 0.092 ID X 0.18" OD, STL	78189	1202-00-00-0541C
-85	210-0405-00		1	.	NUT, PLAIN, HEX.: 2-56 X 0.188 INCH, BRS -----*-----	73743	2X12157-402
-86	337-1767-00		1	.	SHIELD, ELEC: ATTENUATOR, REAR CENTER	80009	337-1767-00
-87	337-1768-00		1	.	SHIELD, ELEC: ATTENUATOR, FRONT CENTER	80009	337-1768-00
-88	337-1766-00		1	.	SHIELD, ELEC: ATTENUATOR, PERIPHERAL	80009	337-1766-00
-89	343-0213-00		1	.	CLAMP, LOOP: PRESS MT, PLASTIC	80009	343-0213-00
-90	380-0244-00		3	.	HOUSING, SWITCH: POLYCARBONATE	80009	380-0244-00
-91	401-0127-01		2	.	ROTOR, ELEC SW: W/CONTACTS	80009	401-0127-01
-92	401-0127-02		1	.	ROTOR-CONT ASSY: DELRIN, W/O CONTACTS	80009	401-0127-02
-93	214-1576-01		1	.	DTT-CONT ASSY: 3 CONTACT	80009	214-1576-01
-94	214-1577-01		2	.	DTT-CONT ASSY: 2 CONTACT	80009	214-1577-01
-95	214-1579-00		3	.	SPRING, DETENT: 0.59 ID X 0.08 W X 0.01 THK	80009	214-1579-00
-96	214-1127-00		3	.	ROLLER, DETENT: 0.125 DIA X 0.125 INCH L	80009	214-1127-00
-97	200-1232-00		3	.	COVER, RTRY SW: CIRCUIT BOARD (ATTACHING PARTS)	80009	200-1232-00
-98	210-0405-00		9	.	NUT, PLAIN, HEX.: 2-56 X 0.188 INCH, BRS -----*-----	73743	2X12157-402

Fig. & Index No.	Tektronix Part No.	Serial/Model No. Eff Dscont	Qty	1	2	3	4	5	Name & Description	Mfr Code	Mfr Part Number
1-	200-2262-00	XB066335	2	COVER, VAR RES:	80009	200-2262-00
-98	-----	-----	8	RESISTOR: VARIABLE R320, R340/S340, R375/S375, R395, R420, R440/S440, R476, R480 (SEE EPL FOR PN)		
-99	210-0933-00		8	WASHER, NONMETAL: 0.625" DIA, 0.002 MICA	08530	OBD
-100	260-0723-00		1	SWITCH, SLIDE: DPDT, 0.5A, 125VAC	79727	GF126-0028
-101	260-0984-00	B010100 B052399	3	SWITCH, SLIDE: DP3T, 0.5A, 125V	79727	G-128-S-0012
	260-0984-01	B052400	3	SWITCH, SLIDE: DP3T W/PLASTIC PLATE	79727	G-128SPC/
-102	129-0398-00		2	POST, CONTACT: FOR JACK TIP	80009	129-0398-00
-103	179-1846-00		1	WIRING HARNESS, : CHASSIS	80009	179-1846-00
-104	131-0707-00		14	CONNECTOR, TERM.: 22-26 AWG, BRS& CU BE GOLD	22526	47439
-105	131-0621-00		5	CONNECTOR, TERM.: 22-26 AWG, BRS& CU BE GOLD	22526	46231
-106	210-0774-00		1	EYELET, METALLIC: 0.152 OD X 0.245 INCH L, BRS	80009	210-0774-00
-107	210-0775-00		1	EYELET, METALLIC: 0.126 OD X 0.23 INCH L, BRS	80009	210-0775-00
-108	352-0162-00		1	HLDR, TERM CONN: 4 WIRE BLACK	80009	352-0162-00
-109	352-0163-00	B010100 B054130	2	CONN BODY, PL, EL: 5 WIRE BLACK	80009	352-0163-00
	352-0164-00	B054131	1	CONN BODY, PL, EL: 6 WIRE BLACK	80009	352-0164-00
	352-0165-00	XB054131	1	CONN BODY, PL, EL: 7 WIRE BLACK	80009	352-0165-00
-110	352-0202-00		1	HLDR, TERM CONN: 6 WIRE BLACK	80009	352-0202-00
-111	200-1480-01		2	COVER, SLIDE SW: MEDIUM GRAY PLASTIC	80009	200-1480-01
-112	200-1480-00		1	COVER, SLIDE SW: DARK GRAY PLASTIC	80009	200-1480-00
-113	200-1480-02		1	COVER, SLIDE SW: LIGHT GRAY PLASTIC	80009	200-1480-02
-114	333-1655-01		1	PANEL, SIDE: 80009 333-1655-01		
-115	-----	-----	2	LAMP ASSY: (SEE DS310, DS535 EPL)		
	-----	-----	-	EACH LAMP ASSY INCLUDES:		
-116	131-0707-00		2	CONNECTOR, TERM.: 22-26 AWG, BRS& CU BE GOLD	22526	47439
-117	352-0169-00		1	HLDR, TERM CONN: 2 WIRE BLACK	80009	352-0169-00
	352-0360-00	B010100 B054579	2	HOLDER, LED: 0.086 ID X 0.20 I OD, PLSTC	80009	352-0360-00
	352-0360-01	B054580	1	HOLDER, LED: 212/214	80009	352-0360-01
-118	179-1992-00		1	WIRING HARNESS: SINGLE SWEEP	80009	179-1992-00
-119	131-0707-00		6	CONNECTOR, TERM.: 22-26 AWG, BRS& CU BE GOLD	22526	47439
-120	352-0199-00		1	CONN BODY, PL, EL: 3 WIRE BLACK	80009	352-0199-00
	010-0262-01	B010100 B053004	1	PROBE, VOLTAGE: 242, 48.55 L, PROBE ONLY	80009	010-0262-01
	010-0262-05	B053005	1	PROBE, VOLTAGE: 1 MEG OHM/1 MEG OHM, DARK	80009	010-0262-05
	010-0262-02	B010100 B053004	1	LEAD, TEST: 1 X, LIGHT GRAY	80009	010-0262-02
	010-0262-04	B053005	1	PROBE, VOLTAGE: 1 X	80009	010-0262-04
	-----	-----	-	EACH PROBE INCLUDES:		
-121	013-0107-02		1	TIP, TEST PROD: RETRACTABLE HOOK	80009	013-0107-02
-122	175-1288-03	B010100 B053004	1	CABLE ASSY, RF: 94 OHM COAX, 49.125 L	80009	175-1288-03
	175-1498-01	B053005	1	CABLE ASSY, RF:	80009	175-1498-01
	-----	-----	-	CABLE INCLUDES:		
-123	175-0940-00	B010100 B053004	1	LEAD, ELECTRICAL: STRD, 24 AWG, 12.5 L	80009	175-0940-00
	175-0940-01	B053005	1	LEAD, ELECTRICAL: PROBE COMMON W/CLIP	80009	175-0940-01
	-----	-----	-	WIRE INCLUDES:		
-124	200-1281-00	B010100 B053004X	1	CABLE NIP, ELEC: 0.125 ID-0.174 SQ X 0.75	80009	200-1281-00
-125	200-1280-00	B010100 B053004X	1	COVER, ELEC CLIP: YELLOW VINYL	80009	200-1280-00
-126	344-0024-00	B010100 B053004X	1	CLIP, ELECTRICAL: ALLIGATOR TYPE	76545	56896-000
-127	214-0592-00	B010100 B053004X	1	CONTACT, ELEC: 0.429 INCH LONG	71785	318-20-00-003
-128	204-0490-03	B010100 B053004	1	BODY, TEST PROD: DARK GRAY	80009	204-0490-03
	204-0594-01	B053005	1	BODY ASSY, PROBE: 1X	80009	204-0594-01
-129	204-0490-05	B010100 B053004	1	BODY, TEST PROD: LIGHT GRAY	80009	204-0490-05
	204-0594-02	B053005	1	BODY ASSY, PROBE: 1 MEG OHM/1 MEG OHM SILVER	80009	204-0594-02

ACCESSORIES

+

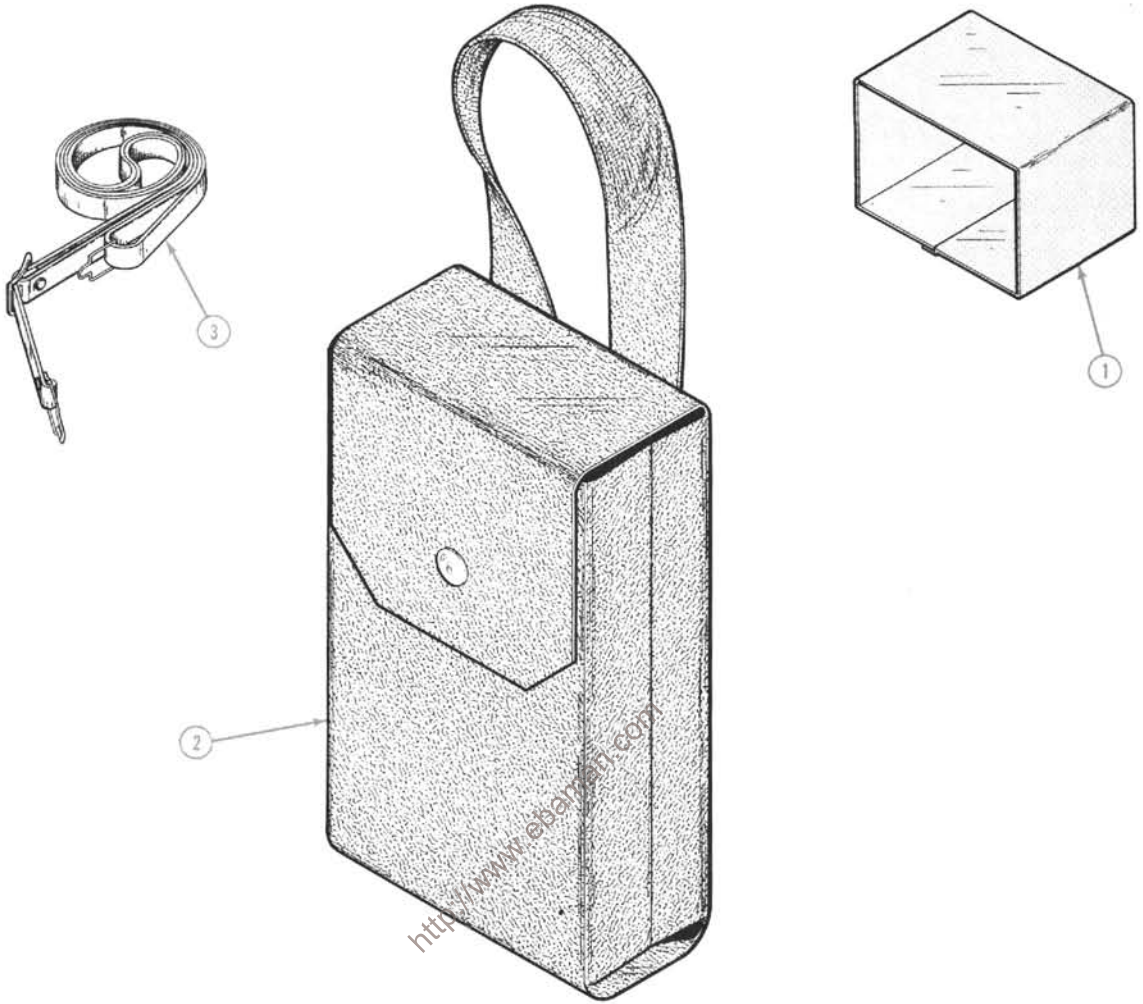

Fig. & Index No.	Tektronix Part No.	Serial/Model No.		Qty	1	2	3	4	5	Name & Description	Mfr	
		Eff	Dscont								Code	Part Number
2-1	016-0199-01			1						VISOR, CRT:FOLDING	80009	016-0199-01
-2	016-0512-00			1						CASE, CARRYING:	80009	016-0512-00
-3	346-0104-00			1						STRAP, CARRYING:	80009	346-0104-00
	070-1482-00			1						MANUAL, TECH: OPERATORS	80009	070-1482-00
	070-1483-00			1						MANUAL, TECH: INSTRUCTION	80009	070-1483-00

MANUAL CHANGE INFORMATION

At Tektronix, we continually strive to keep up with latest electronic developments by adding circuit and component improvements to our instruments as soon as they are developed and tested.

Sometimes, due to printing and shipping requirements, we can't get these changes immediately into printed manuals. Hence, your manual may contain new change information on following pages.

A single change may affect several sections. Since the change information sheets are carried in the manual until all changes are permanently entered, some duplication may occur. If no such change pages appear following this page, your manual is correct as printed.

SERVICE NOTE

Because of the universal parts procurement problem, some electrical parts in your instrument may be different from those described in the Replaceable Electrical Parts List. The parts used will in no way alter or compromise the performance or reliability of this instrument. They are installed when necessary to ensure prompt delivery to the customer. Order replacement parts from the Replaceable Electrical Parts List.

CALIBRATION TEST EQUIPMENT REPLACEMENT

Calibration Test Equipment Chart

This chart compares TM 500 product performance to that of older Tektronix equipment. Only those characteristics where significant specification differences occur, are listed. In some cases the new instrument may not be a total functional replacement. Additional support instrumentation may be needed or a change in calibration procedure may be necessary.

Comparison of Main Characteristics

DM 501 replaces 7D13		
PG 501 replaces 107 108	PG 501 - Risetime less than 3.5 ns into 50 Ω . PG 501 - 5 V output pulse; 3.5 ns Risetime	107 - Risetime less than 3.0 ns into 50 Ω . 108 - 10 V output pulse 1 ns Risetime
PG 502 replaces 107 108 111	PG 502 - 5 V output PG 502 - Risetime less than 1 ns; 10 ns Pretrigger pulse delay	108 - 10 V output 111 - Risetime 0.5 ns; 30 to 250 ns Pretrigger pulse delay
PG 508 replaces 114 115 2101	Performance of replacement equipment is the same or better than equipment being replaced.	
PG 506 replaces 106 067-0502-01	PG 506 - Positive-going trigger output signal at least 1 V; High Amplitude output, 60 V. PG 506 - Does not have chopped feature.	106 - Positive and Negative-going trigger output signal, 50 ns and 1 V; High Amplitude output, 100 V. 0502-01 - Comparator output can be alternately chopped to a reference voltage.
SG 503 replaces 190, 190A, 190B 191 067-0532-01	SG 503 - Amplitude range 5 mV to 5.5 V p-p. SG 503 - Frequency range 250 kHz to 250 MHz.	190B - Amplitude range 40 mV to 10 V p-p. 0532-01 - Frequency range 65 MHz to 500 MHz.
SG 504 replaces 067-0532-01 067-0650-00	SG 504 - Frequency range 245 MHz to 1050 MHz.	0532-01 - Frequency range 65 MHz to 500 MHz.
TG 501 replaces 180, 180A 181 184 2901	TG 501 - Trigger output-slaved to marker output from 5 sec through 100 ns. One time-mark can be generated at a time. TG 501 - Trigger output-slaved to market output from 5 sec through 100 ns. One time-mark can be generated at a time. TG 501 - Trigger output-slaved to marker output from 5 sec through 100 ns. One time-mark can be generated at a time.	180A - Trigger pulses 1, 10, 100 Hz; 1, 10, and 100 kHz. Multiple time-marks can be generated simultaneously. 181 - Multiple time-marks 184 - Separate trigger pulses of 1 and 0.1 sec; 10, 1, and 0.1 ms; 10 and 1 μ s. 2901 - Separate trigger pulses, from 5 sec to 0.1 μ s. Multiple time-marks can be generated simultaneously.

NOTE: All TM 500 generator outputs are short-proof. All TM 500 plug-in instruments require TM 500-Series Power Module.

DESCRIPTION

EFF SN B109195-up

TEXT, REPLACEABLE ELECTRICAL PARTS, AND SCHEMATIC DIAGRAM CHANGES

Text

Page 3-5 preceding Recalibration After Repair title

ADD:

Selectable Components. Resistor R388 value is selected for a switching unblanked trace height of no more than 1.5 divisions for each channel and minimum intensity change when changing sweep speeds from 5 ms to 2 ms. The value of R388 is selected from a range of 270, 300, or 330 ohms as follows:

1. Install a 270 ohms resistor for R388, turn the 214 on, set SEC/DIV to .5 s, and set INTENSITY to maximum (fully clockwise).
2. The traces will show as dots. Set CH 1 POS to place the CH 1 dot to the top horizontal graticule line and set CH 2 POS to place the CH 2 dot to the bottom horizontal graticule line.
3. Check that no more than 1.5 divisions of unblanked trace extends vertically from each dot.
4. If each unblanked trace exceeds 1.5 vertical divisions, turn off the 214, install the next larger size for R388, recheck and repeat steps 2 through 4 until unblanked traces are no more than 1.5 divisions high while maintaining minimum intensity change when switching sweep speed from 5 ms to 2 ms.

Replaceable Electrical Parts List

CHANGE TO:

R388 315-0301-00 RES.,FXD,CMPSN:300 OHM (NOMINAL VAL, SEL)
(SELECTED FROM 270, 300, or 330 OHM)

Schematic Diagram Change

Diagram 2, B1 circuit of Q388 in Partial A1 Input Board area.

CHANGE:

R388 value to SEL